



ÜBER ALLES

Porsche Club of America, Western Michigan Region

August 2012



In this issue:

- **Porsche Corral at Gilmore** – Join us for Gilmore's annual Red Barns Spectacular!
- **Upcoming Events** – Dinner Drive to Schuler's, GAS Open House, Kalamazoo CarFest
- **TechSpalte** – Wheel alignment, and a Pre-Grattan Tech Session at Euro Autowerks
- **WMR's AutoCross** – We're burning up the asphalt at the US-131 Dragway in Martin
- **Annual Grand Prix of Grattan** – Register at clubregistration.net now!

wmr.pca.org



History can repeat itself. It can also top itself.

It is more than the next 911. It is an articulation, from the ground up, of our vision for the future of the sports car. As evidenced by even more power from even less fuel. 350 immensely powerful horses from a 3.4 liter engine in the Carrera. A longer wheelbase for added stability. And a new elevated center console that reinforces our focus on the driver. Proving once again that despite over 60 years of making history, it's making history. And it all starts with a test drive.

The next Porsche 911. Forever the sports car.

Delta Imports
6025 28th Street SE
Grand Rapids MI 49546
(616) 988-9797
www.DeltaPorsche.com
Mon & Wed 9 AM-8PM
Tues, Thurs & Fri 9 AM-6 PM
Sat 10 AM-4 PM

Porsche recommends **Mobil 1**



PORSCHE



PORSCHE



ÜBER ALLES

- 4 President's Letter
- 5 Upcoming: Gilmore Red Barns Spectacular
- 6 Upcoming: August DD
- 7 Upcoming: An August of Fun
- 8 WMR Calendar
- 9 Upcoming: WMR's Pre-Grattan Weekend
- 10 TechSpalte: Wheel Alignment
- 11 Annual Grand Prix of Grattan
- 12 What Porsche Means to Me
- 13 July Meeting Minutes
- 14 Classifieds

Über Alles August 2012 Issue

Published monthly by the Western Michigan Region of the Porsche Club of America

Please send submissions and advertising content to:

Daniel N. Phillips
2676 Briarwood Ct SE
Kentwood, MI 49512
dphil66@hotmail.com
phone (616) 281-2459

Advertising Rates:

- Full page: \$105/mo (color) or \$70/mo (B&W)
- 1/2 page: \$70/mo (color) or \$45/mo (B&W)
- 1/4 page: \$45/mo (color) or \$30/mo (B&W)
- 1/8 page: \$30/mo (color) or \$20/mo (B&W) (business-card size)
- Classifieds: Free for WMR members, \$3 for non-region PCA members, \$5 (2 lines) or \$10 (4 lines) for non-PCA members (3 months)

Note: Color ads receive premier placement (inside of front and rear covers) for maximum exposure.

Please make checks payable to WMR PCA



Hot Summer Days to Remember

John Walters
President, Western Michigan Region

Porsche Parade 2012 was my first parade. There were so many activities, the week just flew by. The Concours field on Monday was amazing! A 1952 Glockler/Porsche won its class, people's and celebrity's choice. Driving tours, TSD Rally, Technical and Historic quiz, and banquets filled the rest of the week. There were plenty of activities for the young crowd as well. Salt Lake City has a very vibrant downtown scene with lots of chic restaurants and shops. The Grand America complex was a do-able walk from the center of town. I drove about 4,000 miles on this trip and loved every minute of it.



Porsche Parade 2013 in beautiful Traverse City will be an unbeatable venue. Salt Lake City has the mountains, but the great lakes and northern Michigan charm will be unforgettable. Many people at this year's Parade remember fondly the 1989 event and wish to come back to Michigan. I and the other board/parade chair members will work hard on this class showing.



August and September offer a number of opportunities to get together and look at cars (or possibly drive them fast at Grattan or the IROC at the US-131 Speedway in Martin). Hoping to see many of you at Schuler's in Marshall (I've never been, but it has been a dining destination for decades) on August 11th. There are also a couple of non PCA events – the 2nd annual Kalamazoo carfest and the 28th Street Metro Cruise. The first week of September provides a chance to enjoy a day on one of Grand Rapids' premier golf courses – Egypt Valley. Lots of activities to finish out the summer! And, special congratulations to Steve & Linda Williams, celebrating 35 years of WMR PCA!

Officers



President:
John Walters
2578 Selkirk Lake Dr
Shelbyville, MI 49344-9525
(269) 672-5055
jwalters@wmis.net
1988 Porsche 911 Coupe



Secretary:
Brenda Hildon-Kaempf
637 South Shore Dr.
Kalamazoo, MI 49002-6942
(269) 370-9183
blue911rsr@charter.net
1995 Porsche 993 'The Beast'



Vice President:
Len Gawron
935 Sterling Ct
Norton Shores, MI 49441
(231) 670-3274
lagawron@comcast.net
2009 Porsche 911 C4S Cab



Treasurer:
Amber Door
645 Summerset Dr.
Jenison, MI 49428-7938
(616) 457-4515
amdoor242@aol.com
1984 Porsche 911 Coupe

Upcoming Events: Gilmore Red Barns Spectacular

04 Aug

Porsche Corral at the Gilmore Car Museum's Annual Red Barns Spectacular

Hosts: Amber Door & Jerry Arens

Your Western Michigan Region of the Porsche Club of America will again be joining over 500 other car enthusiasts (and over 1,000 vehicles) for the 32nd annual Red Barns Spectacular at the Gilmore Car Museum. It is West Michigan's 'Grand Daddy' of antique, classic and special interest car shows. Our Region will have a Porsche-only car corral located on the north end of the race track, located on the west side of the museum grounds.



You may enter your 1987 and older Porsche in the People's Choice category. Feel the need to Detail? Then enter it in the Judges Choice category (open for 1987 and older vehicles)! You must register separately for this portion of the event. Register the day of, or, Red Barn Car Show registration and information can be found at:



http://www.gilmorecarmuseum.org/html/events_details.php?event_id=14&nav_id=5&

- \$15.00 for show cars (includes admission for car and 2 people)
- \$9.00 for general admission (Corral Cars)
- Free for children under 11

Pack a lunch, or purchase food at the Blue Moon Diner.

Porsche enter through the west entrance. All others will be directed to the east entrance. Questions? Email Amber Door at amdoor242@aol.com.



Where: Gilmore Car Museum
6865 Hickory Road
Hickory Corners, MI 49060

When: Saturday, 04 August 2012
9:00 am – 4:00 pm
Gates open at 7:00 am

New Members: *Willkommen!*

Tom & Marian Benedict – Big Rapids, MI
2012 Porsche 911
Cameron Bowman & Eric Snyder – Wyoming, MI
1985 Porsche 944
Gregg DeWitt – Ada, MI
2012 Porsche 911
Larry Lunt – Alanson, MI
1995 Porsche 911 Targa
Amar Meda Prakash – Grand Rapids, MI
2007 Porsche 911
Larry & Jeanne Rist – Lisle, IL
2008 Porsche Boxster
Verna Surprenant & Tom Harris – Norton Shores, MI
2002 Porsche Boxster
Ralf & Denise Ford – Traverse City, MI
1985 Porsche 911 Cabriolet
Tom & Jacqueline McDonald – North Canton, OH
1988 Porsche 944 Turbo

August Anniversaries: *Glückwünsche!*

1 year (2011)	James Brown Mike Carey Jeff Krisel
10 years (2002)	Eric & Lina Spross
35 years (1977)	Steve & Linda Williams

Upcoming Events: August Dinner Drive

11 Aug

August Dinner Drive to Schuler's Restaurant in Marshall, MI

Host: Dan & Ren Phillips

Visiting this far-flung corner of our region will be sure to please as we wind through scenic backroads to Schuler's Restaurant in Marshall, MI this coming August.



Family-owned Schuler's has been a fixture in the small community of Marshall since 1909, and is still making a name for itself today. Hans Schuler was honored as "National Restaurateur of the Year" by Independent Restaurateur Magazine, and helped form the local Tasters Guild chapter in Marshall.

So join us for a spirited drive through winding roads and picturesque farmland on a sunny Saturday in August...take a break from your busy summer, and unwind with us as we relax with a great meal and a glass of cheer, after blowing some serious carbon out of our exhausts!

Start: Park-n-Ride at the US-131 / M-179 (129th Ave) interchange
(Baldwin exit on US-131, just south of Wayland)

(You can gas-up in Wayland beforehand if needed.)

Saturday, 11 August 2012

Arrive 4:00 pm, depart at 4:30 pm

Arrive: Schuler's Restaurant
115 S. Eagle Street, Marshall, MI 49068
(269) 781-0600

Arrive ~6:00 - 6:15 pm



Please RSVP to Dan Phillips at (616) 281-2459 or email dphil66@hotmail.com **not later than August 8th.**

Chairpersons

Über Alles Editor:

Dan Phillips
(616) 281-2459
dphil66@hotmail.com

Chief Driving Instructor:

Terry Schieble
(269) 329-1578
no39rsr@sbcglobal.net

Membership Chair:

Jerry Arens
(616) 457-4515
jdarens62@aol.com

Webmeister:

Michael Betz
wmr.pca.org
mmbetz@image-stream.com

AutoCross Event Chair:

Duane Weed
(231) 937-5420
duane@dwvideo.com

Registrar:

Amber Door
(616) 457-4525
amdoor242@aol.com

Interim Advertising Co-Chair:

Ted Blacklidge
(616) 866-4143
sgrafex@chartermi.net

Safety Chair:

Craig Ackerman
(616) 866-1905
pcaackerman@aol.com

WMR Enthusiast:

Marshall Walters
(269) 672-5055
marshall.walters@towerswatson.com

Interim Advertising Co-Chair:

John Walters
(269) 672-5055
jwalters@wmis.net

Historian & Insurance Coordinator:

Kurt Wirth
(616) 956-0249
kurtwirthsc356@comcast.net

Zone 4 Representative:

Ron Carr
(740) 967-6027
zone4rep@embarqmail.com

Upcoming Events: An August Full of Fun!

18 Aug

4th Annual German Auto Open House

We welcome you and your family to our 4th annual Open House! Join us from 10:00 am – 2:00 pm for a free car show, door prizes, free food, and tours of our facility. Everyone is invited, so feel free to bring your neighbors, co-workers, and friends.

Car show judged by attendees is open to all European makes. Pre-register by emailing benz@germanautoltd.com or calling (800) 260-8000. Participants must arrive by 9:30 to sign in.

Location: German Auto Service, 1014 Scribner NW, Grand Rapids, MI



18 Aug

2nd Annual Downtown Kalamazoo CarFest – Downtown Kalamazoo, MI

Downtown Kalamazoo's CarFest invites owners to display their specialty cars of all kinds, side-by-side, throughout downtown Kalamazoo. Hundreds of cars are anticipated, and a full schedule of family fun is planned.

Sign-in begins at 7:00 am on South Street, and cars will be on display from 10:00 am – 5:00 pm. Pre-register for only \$10 by August 10th, download the form at CarFestKzoo.com. Register now, all spots are first-come, first-served, and will be going fast!



24 Aug

28th Street Metro Cruise – Delta Porsche, Grand Rapids, MI

On the afternoon of August 24, Delta Imports welcomes you to the annual 28th Street Metro Cruise.

After 5:00 pm, join us at Delta Imports, 6025 28th Street SE, Grand Rapids, MI. Park your Porsches on our lot along 28th Street, and enjoy the sights and sounds of local classic and exotic cars cruising down 28th Street as this car enthusiasts' weekend gets into high gear!



26 Aug

WMR PCA's Annual AutoCross Driving Event (IROC III)

Duane Weed, WMR AutoCross Event Chair

Every year, we melt the pavement at Grattan in early September. This is well-known. But less well-known is our Annual AutoCross event.

If you've never experienced an AutoCross event, come out and try your hand at it. Or just come out to watch – it's mega-entertaining either way. And it's the cheapest way (25 bucks!) for you to get some real track time in your car, in a safe and controlled environment, and even with (*gasp*) timing equipment!

We compete against the clock, one person at a time on the course, for Fastest Time of the Day in our class. Doesn't that sound like...a really great time? You can learn how to properly hustle your car through a tight road course, and best of all, get some good practice at it. You might even impress yourself with a Fastest Time of the Day trophy!

Please be sure you have your car properly and safely set up for the track. All the tech rules of DE events apply to AutoCrossing, including the rollover protection and helmet requirements (Snell 2005 or newer, SA or M rated.)



Please contact Duane Weed at (231) 937-5420, or email duane@dwvideo.com for any questions relating to this event. See you there!

When: 26 August 2012

Registration / Tech Inspections – 9:00 am; Track Walk – 10:30 am

Runs Begin – 11:00 am. Day ends by mid-afternoon

Where: US-131 Dragway, Martin, MI "The Fastest Track in Michigan"

2012 Calendar

Porsche Club of America

Western Michigan Region



August	4	Gilmore Car Museum Red Barns Spectacular – Hickory Corners, MI <i>Hosts: Amber Door & Jerry Arens</i>
	6	Monthly Board Meeting – Delta Imports, Grand Rapids, MI
	11	August Dinner Drive – to Schuler's in Marshall, MI <i>Hosts: Dan & Ren Phillips</i>
	15-19	Porsche 356 Registry's 2012 East Coast Holiday – Boston, MA <i>Porsche 356 Registry Event (http://www.ech2012.com/)</i>
	18	2nd Annual Kalamazoo Car Fest – Kalamazoo, MI <i>Non-PCA Event, c/o Michael Betz</i>
	18	German Auto Open House – German Auto Service, Grand Rapids, MI <i>Non-PCA Event, c/o German Auto Service</i>
	24	28th Street Metro Cruise – Delta Porsche, Grand Rapids, MI
	26	IROC III, the annual WMR Autocross – US 131 Dragway, Martin, MI <i>Host: WMR PCA, c/o Duane Weed</i>
September	7-9	Boxstoberfest 2012 – Fredericksburg, TX <i>Non-PCA Event</i>
	7	4th Annual Golf Outing – Egypt Valley Country Club, Ada, MI <i>Hosts: Arnie & Val Axelrod</i>
	8	Pre-Grattan Tech Session – Euro Autowerks, Rockford, MI <i>Host: Tim Thatcher</i>
	10	Monthly Board Meeting – Delta Imports, Grand Rapids, MI
	15-16	Grand Prix of Grattan DE – Grattan Raceway, Grattan, MI <i>Event Chair: Ted Blacklidge</i>
	TBD	September Dinner Drive – Traverse City, MI <i>Host: TBD</i>
	21-29	Porsche Club Ocean Cup Sailing Regatta – Marmaris to Fethiye, Turkey <i>Host: Porsche Club Russland / Porsche Clubs Coordination</i>
29-30	Cincinnati VW Club's VW-Porsche Reunion – Cincinnati, OH <i>Non-PCA Event – Cincinnati VW Club (http://cincyvwclub.com)</i>	
October	1	Monthly Board Meeting – Delta Imports, Grand Rapids, MI
	13	Annual Fall Color Tour – Location TBD <i>Hosts: Jim & Ardis Schaaf, Len & Bonnie Gawron</i>
November	5	Annual Planning Dinner – Location TBD
	8-11	PCA Escape 2012 – Eureka Springs, AR <i>PCA National Event (http://www.pca.org/Activities/Escape.aspx)</i>
December	TBD	November Dinner Drive – Location TBD <i>Host: TBD</i>
	3	Monthly Board Meeting – Delta Imports, Grand Rapids, MI
	8	December Appetizer Party – Shelbyville, MI <i>Hosts: John & Marshall Walters</i>

For more PCA National and Inter-Regional events, visit <http://www.pca.org/Activities.aspx>.

For the full PCA Club Racing Schedule, visit <http://www.pca.org/Activities/ClubRacing/Schedule.aspx>.

Upcoming Events: Pre-Grattan Weekend

07 Sep

WMR PCA's 4th Annual Golf Outing at Egypt Valley Country Club

Hosts: Arnie and Val Axelrod

Men and women are encouraged to sign up for this fun event at Egypt Valley Country Club. This is one of the finest golf courses in this part of the country. For 10 Years, EVCC hosted a PGA Champions Tour Event, and has hosted the USGA Junior Men's tournament. The course is in great shape, so come out and join us and your Western Michigan Region friends for a great round of golf. For those who wish, the patio will be open for dinner and/or drinks when we finish. Order off the menu with separate check. Cost including cart is \$80.00 per person. Credit cards only - sorry, no cash.



Reservations to Arnie at amaxelrod@att.net, or call (616) 676-1330 by 8/31. Limited spaces available. Late participants on a best-effort basis. Make your reservation early.

Time & Cost: Tee Times begin at 2:00 PM.
\$80.00 per person includes 18 holes and cart.

Location: Egypt Valley Country Club, 7333 Knapp Avenue NE, Ada, MI



08 Sep

2012 WMR PCA Open House and Porsche Tech Session at Euro Autowerks, Inc.

Host: Tim Thatcher

Join us September 8th for our Annual Open House and Tech Session. Listen and learn as Master Technician and PCA member Tim Thatcher, explains how proper tire alignment and corner balance can give you the edge in performance and safety, whether on the track or on the road.

Lunch from the grill will be served following a question and answer session.

Examine the latest project car to be completed, enjoy good food, receive a free gift and participate in a drawing for some super prizes. We guarantee you will have a great time!

We are located at 9240 Belding Road (M44) between Ramsdell Rd and Grattan Raceway. Doors will open at 10AM; the Tech Session begins at 10:30AM. Please RSVP to admin@euroautowerks.com.





TechSpalte: Tire Alignment

Contributed by WMR PCA member Tim Thatcher, ASE-Certified Master Technician and Owner, Euro Autowerks

Keeping your tires aligned properly will save you money and provide you with a car that handles like it should. This article attempts to give you an overview of the factors that make up tire alignment.

TOE is the difference in distance between the front of the opposing tires as compared to the rear of them.

Incorrect toe will result in the tires wearing in at a feathering angle across the surface. Toe is often set at 0 (zero) or with just a slight bit of toe in (tires closer at front), which helps the higher speed stability of the vehicle.

If tires are in a toe out condition, (see picture above) it can cause an unstable feel in the steering of the vehicle.

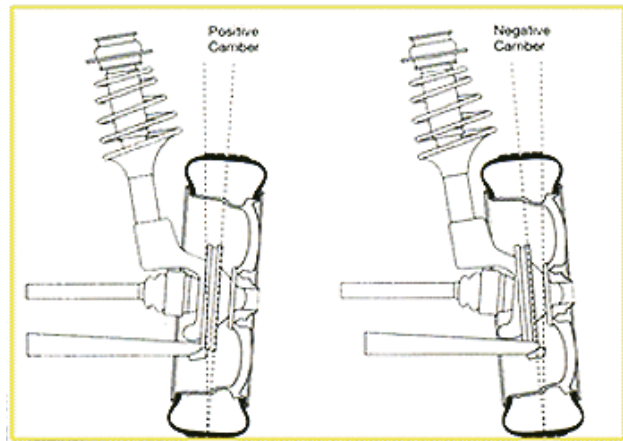
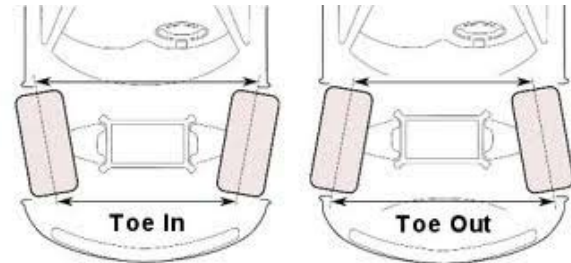

Camber Angle Diagram

CAMBER is the angle of the tire as viewed from the front of the vehicle.

If the top of the tire is leaning in, that means it has negative camber. If the top leans out, that would result in positive camber. Too much negative camber will wear the inside edge of the tire, too much positive camber wears the outside edge.

CASTER is the angle of the tire as it turns or pivots around the suspension pick-up points or the upper and lower ball joints as viewed from the side of the car.

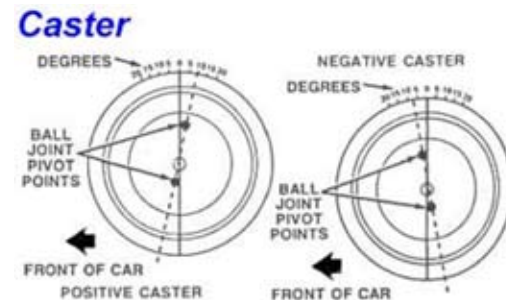

When the top of the tire leans to the rear of the car, this is referred to as negative caster. If the top leans to the front of the car, it's referred to as positive caster.

Caster affects high speed turning or stability and helps the steering wheel return to center after a turn. If caster is off from one side of the vehicle to the other side, it will make the car pull to one side or the other.

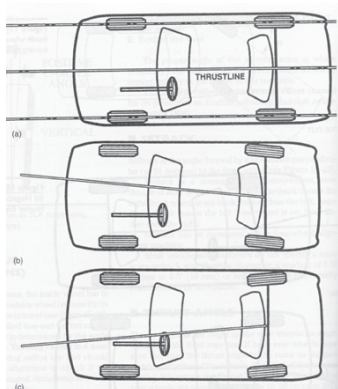

Thrust Angle Diagram

THRUST ANGLE is the direction the rear wheels are pointed in relation to the front tires.

If the thrust angle is not correct, the car will "dog track", that is the rear of the vehicle follows to one side or the other of center.

Well maintained suspension parts are critical to the performance and safety of your vehicle, yet they are some of the most overlooked parts. Having your tires aligned regularly and maintaining the suspension system will provide you with a safe and enjoyable driving experience.

We hope you are enjoying this great driving weather!

Upcoming Events: Annual Grand Prix of Grattan

15-16
Sep

WMR PCA's Annual Driver Education Event: Grand Prix of Grattan

Ted Blackledge, DE Chair

We welcome you to our annual Driver Education event, the annual Grand Prix of Grattan DE! If you're a novice or an expert, this is one of the best tracks to learn and practice. Don't be shy! Come out and enjoy the fun as a driver or spectator alike!

This year, registration will be exclusively through clubregistration.net. There will be no paper applications accepted this year, so if you don't already take advantage of this far-superior system, take a few minutes to set up an account and register online at clubregistration.net. REGISTRATION IS OPEN NOW.

As always, all the usual tech inspections and rules apply, including the requirements for a brake fluid change within 2 months of the event, and the requirement for added rollover protection that meets the 'broomstick rule', if your car is not equipped with factory rollover protection. And as was new last year, your helmet must be rated Snell SA2005 or M2005 or newer. Please visit www.pcahpdeins.locktonaffinity.com for information on PCA-sanctioned single event insurance coverage.



Foreign Car Services, Inc.

1104 Portage Street
Kalamazoo, MI 49001
(269) 342-6994

COMPLETE AUTOMOTIVE SERVICE AND
QUALITY WORKMANSHIP SINCE 1987.
HOURS: MONDAY - FRIDAY, 7:30AM TO
6:00PM, CLOSED SATURDAY & SUNDAY

PORSCHE SPECIALISTS
Bosch Authorized Service Center

Our Master Mechanics can handle anything your car needs, from a "pre-purchase" vehicle inspection or diagnostic inspection, to a complete engine overhaul or a routine tune-up. Come in for an estimate today!

We Service:

Acura, Audi, BMW,
Honda, Lexus, Mazda,
Mercedes, Nissan,
Porsche, Saab, Toyota,
Volkswagen & Volvo.

GERMAN AUTO Service, LTD.

Serving the West Michigan Porsche
community for over 30 years!

- Routine maintenance to track proven upgrades
- Outstanding customer service
- State of the art diagnostic equipment
- ASA master certified technicians
- Free shuttle service
- Conveniently located near downtown Grand Rapids

**10% OFF PARTS FOR
PORSCHE CLUB MEMBERS!**



(800) 260-8000
www.germanautoltd.com
1014 Scribner NW
Grand Rapids, MI 49504



Member Profile: What Porsche Means to Me

Contributed by Don Sazama

In late 2007, I decided it was time to start looking for another Corvette. Helen and I had owned 1965, 1968, 1969 and 1970 models. I decided that a nice 1967 big block coupe with air conditioning would be just right. After some research, I found that the price for a nice original car was somewhere north of 6 digits. Seemed like a lot of money for a car that you would be afraid to drive or leave in a parking lot somewhere.

I have some friends that had purchased used 911s and one neighbor had a 1997 Carrera S. It was time to see what Porsche was all about. I had never been in one and had no idea what to expect. Delta Porsche had a 2005 Carrera S, so I went for a ride one day with Charles. I was amazed at the power and the handling. Too bad he would not come down in price. It was a gorgeous black coupe, just the color I wanted.

I spent several months searching the internet, eBay, and Craig's list, and made many phone calls all over the country. There were many disappointments when the car I wanted was already sold.

I saw an ad in Panorama in April of 2008. A 2004 C4S with 7,000 miles. Unfortunately, it was seal gray metallic, not black, but it was in Okemos, only an hour away. I met the owner at the dealership and Helen and I went for a test drive. I had seen pictures of the car and decided that the color was ok. We made a deal, and the car was ours in May.

Then in September of 2008, I attended my first HPDE. It was at Grattan and I had no idea what to expect. My previous track experience was in the 1970s with autocrossing and some tracks at old airbases. I had done well in competition, but had never seen a track with the elevation changes that Grattan has. All turned out well, and as they say, "the hook was set".

I drove the car to Florida that winter and went to a NASA DE at Homestead/Miami Speedway. After new tires and front rotors, the hook went even deeper. I did several lapping days in 2009 and 2010 at local tracks. In 2011, we purchased a Cayenne S and a trailer and did more traveling. 2012 brought suspension, roll bar/harness and various other changes. I have made all the modifications so I can restore the car to total stock condition someday. (I do miss the power seats.)

I am thankful that Helen enjoys our long weekends at various tracks and finds so many alternate routes that keep us off the expressways.

It has been a pleasure associating with fellow Porsche owners. It is definitely the people!





WMR Meeting Minutes, 02 July 2012

Delta Imports, Grand Rapids July 2, 2012 – Meeting was called to order by John Walters at 6:59 pm. Members present were: John Walters, Marshall Walters, Amber Door, Ted Blacklidge, Gabi Blacklidge, Rick Riley, Arnie Axelrod, Colin Carpenter, Daniel Bird

Treasurer's Report: Approved

Membership Report: 223 Primary Members, 171 Affiliate Members – total 394. New Members – 7, Transfers In – 1, Transfers Out – 0, Non renewals – 4, Renewals – 18

Minutes: Minutes from June meeting approved.

Über Alles Editor's Report: No report

Webmaster's Report: No report. Web site is up to date

Insurance Report: No report

Old Business:

- June 6 – Gilmore Car Museum Wednesday Night Cruise In – Host Rick Riley & Kurt Wirth. ~ 20 cars throughout the day.
- June 23 – Spring Up to Traverse City – Host Denny & Joyce Weise, Bill Brown. Great turn out.
- Über Alles advertising blast: No response to date.

New Business:

- Charity Update: Gabi Blacklidge to follow up and provide report
- July 28 – WMR PCA Summer party – Host: Craig & Chris Ackerman. No insurance needed; write up completed for Über.
- Aug 4 – Gilmore Car Museum Red Barns Spectacular – Porsche Car Corral – Host: Amber Door & Jerry Arens – Insurance needed; National Car Corral Subsidy received
- Aug 11 – Dinner Drive to Schuler's in Marshall, MI – Host: Dan & Ren Phillips. Leaving from Park & Ride @ Bradley Exit – Exit 61 on US 131
- Name Tags for members attending 1st event – discussion.
- Aug 26 - IROC III – US 131 Motorsports Park. Approval for purchase of new LED lights for Timing Equipment (\$50.00 max). Colin Carpenter to obtain
- 2013 Porsche Parade – update.

Meeting was adjourned at 7:51 pm

Respectfully submitted by Amber Door

Get your WMR PCA Name Badge!

These are very high-quality name badges, permanently printed on a sturdy framed plate. The magnetic attachment won't damage your clothes. Cost is \$15 each, free shipping! Please send your check and correct name spelling to:

John Walters
2578 Selkirk Lake Dr
Shelbyville, MI 49344-9525

Please make your check payable to WMR PCA.

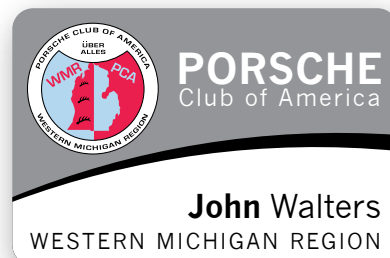



Classifieds

2001 PORSCHE 911 CARRERA CABRIOLET – Midnight Blue Metallic exterior, Metropol Blue top and leather seats, Tiptronic, removable hardtop, under 30,000 miles, indoor winter storage, beautiful condition. \$34,000. Contact John Hanson at (248) 701-8608 (Grand Rapids, MI). (Aug 2012)

2000 PORSCHE BOXSTER – 9456 miles. Over \$8000 exclusive options: Artic silver, sport package, Nephrite Green special leather, 17” Sport Classic wheels, stainless door sills. Flawless. \$16,000. Contact Frank Wosek at (231) 264-5120 or email Diane Wosek at dfwosek@gmail.com. Former PCA and WMI members. (Aug 2012)

1989 PORSCHE 911 TURBO – Linen Metallic (silver) over grey leather interior. 115k miles, 2nd owner, service by German Auto for the past 14 years. Many mods, very fast. Divorce forces sale. \$38,000. Contact Al Nelson at (231) 690-9092 or email i.xlr8@live.com. (that’s the letter “i”, a period, followed by “xlr8”) (Dec 2011)

1987 PORSCHE 911 TURBO CABRIOLET – Factory slant-nose (one of 216 real 505 factory built and documented), pristine all-original condition, black on black, with Porsche certificate of authenticity. Contact Frank Berris at (616) 887-0956 or email fgberris@americango.biz (July 2011)

1986 PORSCHE 944 – Guards Red. 143,500 miles. 2nd owner (purchased in 1989). Engine rebuilt by Porsche-certified mechanic at 82,725 miles (10.1995). Great-sounding and nice-looking car is improved and very competitive in autocross. Turbo front end with electrics. Expertly maintained by Claudio at FCS. Porsche Evaluation Committee says \$10,710 is average price, asking \$5,999. Call Michael Betz at (616) 460-8880 or email mmbetz@image-stream.com. (Aug 2012)

1985-1/2 PORSCHE 944 - Great 1st Porsche and beginning autocross or track car. Roll bar, Dino steering wheel, Recaro driver’s seat, 17” Cup wheels with Kumho Cector Racer tires. 5-point harnesses plus stock belts. HD springs & swaybars, Koni adjustable shocks, more. Asking \$5,495 OBO. Contact Jim Morgan at (574) 457-2044 or email jimandjudi@hoosier-link.net. (Michiana Region PCA) (Aug 2012)

WHEELS AND TIRES – 16” factory wheels & tires from a Porsche 911 (993), sizes are 205/55-16 front, 245/45-16 rear. \$500 o.b.o. Call Glenn at (269) 751-5644. (July 2011)

911MAX MULTI-CHIP – Fits 1984-1989 Porsche 911. Multiple mappings, including Stock, 93 Octane, Valet (3,000 RPM limit) and No-Start, easily modifiable via external switch, customizable via software. Works w/either 24 or 28-pin DMEs. Price reduced - now only **\$100!** Call Greg Calahan at (616) 617-0369 or email greg@cerulean-group.com. (June 2011)

AUTO DETAILING SERVICE – References available. Call or e-mail Eric at Professional Car Appearance, LLC, (616) 706-4421 or ericpca911@yahoo.com. (Feb 2010)

WANTED – PCM 1st-generation CD-ROMs to copy; I have discs 1, 5, & 6, need the rest. Need maps 1, 5, or 6? I can help. These are NLA from Porsche. Call Dan Phillips at (616) 281-2459 or email dphil66@hotmail.com.

EURO AUTOWERKS

INC.

9240 Belding Rd NE
Rockford, MI 49341
(616) 874-7932
www.euroautowerks.com

Open Mon-Fri 8-5:30
Pickup and Delivery Service
Available, please call for details!



**We specialize in Service and
Restoration for your Porsche!**

**Tim Thatcher,
ASE-Certified Master Technician
PCA member since 1974**



Our full-service shop can take care of your:

Porsche • Audi • VW • Mercedes-Benz • BMW
Saab • Volvo • Honda • Nissan • Toyota
American vehicles

PCA Member Discounts Available!

**Is your car a *dream*,
but your
house
a *nightmare*?**



Remodeling by Morris Builders, Inc.



"A remodel is often times more difficult than new construction because of the parameters already in place... Kirk and Joy Morris, and their professional staff, has been committed, conscientious and caring throughout two major remodels in our home in the past two years. Their attention to detail was exceptional. Also was their willingness to work with us when we knew what we wanted, and their experienced suggestions were helpful when we didn't. Morris Builders will help you make your home as unique as you are."

– Ted & Gabriele Blacklidge, WMR, PCA

Joy Morris • Kirk Morris, CGR, CAPS, CGP
Phone: 616.874.6110 • Fax: 616.874.2904

Email us at: info@morrisbuildersinc.com • Visit our website at: morrisbuildersinc.com
Located in Rockford, MI 49341

WESTERN MICHIGAN REGION,
PORSCHE CLUB OF AMERICA
C/O Dan Phillips
2676 Briarwood Ct SE
Kentwood, MI 49512-9084

PRSRT STD
U.S. POSTAGE
PAID
GRAND RAPIDS, MI
PERMIT NO. 404

Über Alles is the official monthly publication of the Western Michigan Region of the Porsche Club of America, Inc., a non-profit organization registered with the state of Michigan. Statements and opinions appearing herein are those of the authors and do not necessarily represent the opinions of WMR PCA, PCA, its officers or members. The editor reserves the right to edit all material for publication and to publish only the material deemed appropriate and in the best interest of WMR PCA and of PCA. Permission is granted to reprint in whole or in part, provided that A) credit will be given to the author(s), Über Alles, and WMR PCA, B) copyright is not involved, and C) a copy of the article is provided to WMR PCA upon publication. Subscriptions for non-members are \$18.00 annually. Deadline for advertising & new content is on the 20th day of the month prior to the issue month. Über Alles is available electronically at <http://wmr.pca.org/>.



- Hagerty Insurance approved/preferred repair facility.
- Two i-Car certified technicians, each with 10 to 15 years of experience, repairing all makes & models, foreign & domestic.
- We also repair aircraft, motorhomes, cargo and travel trailers, and other recreational vehicles.
- Restoration services available.



Approved & Preferred

Certified



Technicians



Along with our collision services, we also offer professional detailing. Would you prefer 'Joe Wax-a-lot' and a dirty towel, or an expert paint technician using the highest-quality products and equipment?

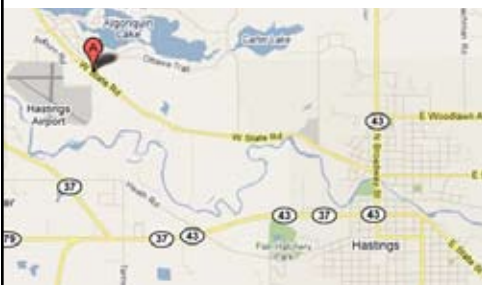

Owned by Rob & Sue Deming,
PCA Members since 1987

2493 W. State Rd.
Hastings, MI 49058
Ph. (269) 945-2922
Fax (269) 945-0320

www.demingsautocollision.com

