

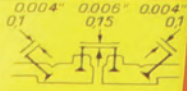

Ventilspiel kalt
Tappet clearance cold
Jeu de poussoir à froid



FRAM
DAS MODERNE
ÖLFILTER
F 900
Nur Original FRAM-Einsätze
der Serie C-900 verwenden!
DEUTSCHE FILTER-GESELLSCHAFT
WUEST & Co. K.G.
MADE IN GERMANY

Über Alles

Porsche Club of America, Western Michigan Region

Let's Get Together:

Kurt Wirth invites you
to the Grattan Pub

In Review:

WinterFest 2015
Morning After Brunch



Porsche recommends **Mobil 1** and **MICHELIN**

Experience a mix of practicality and performance. Although it heavily favors performance.

There's never been a Porsche that serves two masters. And the Cayenne is no exception. Its renowned sports car performance is apparent at every turn. That said, the same ingenuity that makes fuel systems more efficient and traction management systems smarter, serves us in a different respect—practicality. With plentiful seating and creatively appointed storage space, to name just two. Visit our showroom to see the balance work for you. Porsche. There is no substitute.

Experience the thrill of duality. The Cayenne.

Delta Imports

6025 28th Street SE
Grand Rapids MI 49546
(616) 988-9797

www.deltaimports.porschedealer.com

Monday and Wednesday 9:00am - 8:00pm

Tuesday, Thursday and Friday 9:00am - 6:00pm

Saturday 10:00am - 4:00pm



PORSCHE



PORSCHE



IGNITION

MARCH, 2015



President's Letter	4
Upcoming Events	5
Review: Winterfest 2015	6-7
2015 Event Calendar	8-9
Tech Spalte	12
Classifieds	14
The Tailpipe	14-15

DURING MARCH — JOIN US FOR THE READ N' GIVE® BOOK DRIVE



FOX MOTORS · DELTA PORSCHE
6025 28TH STREET SE.,
GRAND RAPIDS, MI 49546



This year, Fox Motors is participating in a book drive to support local students through the *Read n' Give*® program. Fox Motors will be accepting books for children of all ages: Elementary, Middle and High school reading levels. You can find more information on how to donate your old books on the following website: <http://www.readngive.com>

— Shared by Marshall Walters

Über Alles

Porsche Club of America, Western Michigan Region

On the cover:
*The beating heart of a
1965 Porsche 356*
Photo by Kurt Wirth

CARS OF INTEREST

LETTER FROM THE PRESIDENT



Mike Karluk
*President,
Western Michigan Region*

Work kept me from joining a number of our WMR members at the North American Auto Show in Detroit in January. I was able to stop by the Grand Rapids auto show and began with a quick walk through the “unobtainium” gallery of Aston Martins, Ferraris, and Rolls Royces. My ability to walk by these with an appreciative, but cursory glance is probably less a factor of any spiritual evolution on my part than recognition that our Stuttgart stallions offer a far better combination of performance, dependability, and fiscal rationality.

The Lamborghini Huracán, however, did prompt me to stop and gaze longingly. The other car that captured my attention and was out of place in one sense, however, was a white 2015 Corvette Z06. With a base price of \$79,995, this car with it's 6.2-liter supercharged V8 putting out 650-bhp and 650-lb-ft of torque was actually quite obtainable. I quickly moved on through the show finding few cars of interest that I could fit into with my relatively long torso. I barely fit in a Camaro, I couldn't live comfortably with the new Lexus RC-F, and even the

VW Golf, which reminds me of my beloved 1990 Honda Civic Si, was too small. Thank God I have no problems fitting into all current Porsche models.

Our friends from Delta Porsche had a beautiful Boxster GTS on display that with its carbon ceramic brakes and other options weighed in a little north of \$100k. I was then informed that the Cayman GT-4 was being unveiled in Geneva this month and could be ordered. A quick check of the Porsche website revealed this object of my desire to have a base price of \$84,600 for its 3.8-liter flat six making 385 bhp and 309 lb-ft of torque. Porsche appears to be making a statement with the GT-4 by only having a 6-speed manual transmission. With what I considered necessary options, the GT-4 of my dreams priced out around \$92k, almost identical to the Corvette with the Z07 option package.

These are interesting times to have a hankering for spirited driving when such different, but desirable machines are available for roughly the same price. There is absolutely no question in my mind which of the two is prettier (even with that cop-magnet rear wing)!

I hope to see many of you at the Grattan Pub on March 18. Stay warm! — *Mike*

OFFICERS

SERVING YOUR CLUB



Mike Karluk
President,
2001 Porsche 911 Turbo

9342 Whispering Sands Dr.
West Olive, MI 49460
mbkmd9198@charter.net



John Walters
Past President,
1988 Porsche 911 Coupe

2578 Selkirk Lake Dr
Shelbyville, MI 49344-9525
(269) 672-5055
jwalters@wmis.net



Brenda Hildon-Kaempf
Secretary,
1995 Porsche 993
'The Beast'

637 South Shore Dr.
Kalamazoo, MI 49002-6942
(269) 370-9183
blue911rsr@charter.net



Amber Door
Treasurer,
1984 Porsche 911 Coupe

645 Summerset Dr.
Jenison, MI 49428-7938
(616) 457-4515
amdoor242@aol.com

MARCH DINNER DRIVE

HOST: KURT WIRTH

Meeting on what is usually a chilly and often snowy night in March, for the warmth of friends at the Grattan Irish Pub, has become a very popular tradition with our group. So plan on meeting up with us there once again, this coming Wednesday, March the 18th! We'll enjoy the very decent menu of the Pub and of course our favorite Wednesday's all-you-can-eat fish and chips. The cozy atmosphere and good food keeps us coming back and our group keeps getting bigger and bigger every year! Make this year the one you choose to come out and join us! We promise there will be talk about Porsches.

Please RSVP to Kurt at kurtwirthsc356@comcast.net, or call (616) 956-0249. Hope to see you there!

When:

Wednesday, March 18, 2015

6:00 pm Social Hour, Drinks / 7:00 pm Dinner



Can't wait for Spring. Photo by Neil MacDonald, Chicago Region PCA

Where:

Grattan Irish Pub

11817 Old Belding Road NE · Grattan, MI 48809

(616) 794-1691

APRIL MEATLOAF COOKOFF

HOST: TERRY & DORILEE SCHIEBLE

Enter your favorite Meatloaf recipe in the annual **"Porsche Club Cookoff Party & Cookoff Competition"**. On April 18th you're invited to enter your own meatloaf in a crock pot creation and compete for: Judge's Choice, People's Choice, or be an Official Sampler of them all!



Please make at least 1.5 pounds so everyone can have a taste, because "like a bat out of hell it'll be gone when the morning comes." Please bring your own drinks too. (Pop will be available). Prizes will be presented to the Judge's Choice and to People's Choice. We will gather at the home of our gracious hosts Terry and Dorilee Schieble. RSVP is REQUIRED, so please contact Terry or Dorilee by April 10th by phone: (269) 329-1578 or Dorilee's Cell: (269) 910-4306.

Where:

Terry and Dorilee Schieble

726 Lakeview Dr., Portage, MI

When:

Saturday, April 18, 2015

6:30 pm

REVIEW: WINTERFEST 2015

BY BRENDA HILDON-KAEMPF · PHOTOS BY AMBER DOOR

This year's celebration took place at Bar Divani in beautiful downtown Grand Rapids, which was a new venue to us. There were 44 members, including our Zone 4 Representative Michael Soriano and his wife Lisa, in attendance.

Our long distance guests included Greg and Karlene Currie, who made the trek from Traverse City. Located in a former gallery in the historic Blodgett Building, the venue provide a modern yet cozy ambiance, and aside from a few parking hiccups (we definitely weren't the only event in town!), a great evening of food, fun and camaraderie was had by all.

The three Mikes (Mike Karluk, Michael Betz and Michael Soriano) did a great job moving through the program with ease and brevity. Our Enthusiast Chair, Marshall Walters, announced Amber Door as our 2014 Enthusiast of the Year and presented her with the prestigious trophy

(there were 3 members who each achieved over 300 points). Our Board members and event volunteers and hosts were acknowledged and thanked, each receiving a chocolate Porsche courtesy of Mike Karluk's brother.

Gabi Blacklidge provided us with an update on our charity efforts noting that we doubled the previous year's donations. Special thanks to Tim Thatcher and Euro Autoworks for once again providing beautiful custom calendars, Barb Paull for the donated GRAM membership, Rob and Sue Deming and Deming's Auto Collision Service for the Andretti Wine, Marshall Walters and Amber Door for their help with planning, invitations, door prizes and set up, and Amber for the gorgeous men's Porsche belt that was auctioned off for charity.

The evening continued with more smiles, fellowship and laughter, followed by a great brunch the next morning at Charlie's Crab.

REVIEW: MORNING AFTER BRUNCH

BY AMBER DOOR · PHOTOS BY AMBER DOOR

Our frigid Michigan weather did not dissuade the 21 PCA members that ventured to Charlie's Crab for the Morning After Brunch. This year the group included post Winterfest revelers from throughout the region

(plus Terry Schieble who drove up for brunch), in addition to our Zone 4 Rep Michael Soriano and his wife Lisa. Again this year the food and friends around the table made for a great time for all.



After a 3-year hiatus the "Morning After Brunch" returned to Charley's Crab.



Lovely sun outside. Zone 4 VIPs inside: Michael Soriano and his wife Lisa.

WINTER FEST 20

PHOTOS BY
AMBER DOOR

15



We like our chocolate to straddle solid double-yellows, parked Le Mans style and shaped like a Porsche 934. — Jägermeister not included.



Cheers! Michael and Connie Betz enjoying the 2015 WInterFest. Now, that's how you pose for a photo.



Michael Soriano issued our 55th Anniversary certificate. WMR turns 55 in November!



When you're WMRPCA's 2014 Enthusiast of the Year, you can't be afraid of a microphone. Congratulations to Amber Door!



A look around the tables during the WMR PCA Annual Award Show revealed anticipation, contemplation and postprandial somnolence.

2015 EVENT CALENDAR

WESTERN MICHIGAN REGION · PORSCHE CLUB OF AMERICA

	Date	Event	Location	Host(s)/Event Chair(s)
MAR	03-02	Monthly Board Meeting	Delta Imports, Grand Rapids, MI	WMR PCA Club
	03-18	March Dinner Drive	The Grattan Pub, Grattan, MI	Kurt Wirth
APR	04-06	Monthly Board Meeting	Delta Imports, Grand Rapids, MI	WMR PCA Club
	04-18	Annual Cookoff	Schieble Residence, Portage, MI	Terry & Dorilee Schieble
	04-26	Spring Brunch	Cygnus 27, Grand Rapids, MI	Wolfgang & Miluzka Bubeck
MAY	05-04	Monthly Board Meeting	Delta Imports, Grand Rapids, MI	WMR PCA Club
	05-16	May Dinner Drive	Destination TBD	John & Marshall Walters
	05-23	Sporting Clays Event	Blendon Pines Gun Club, Zeeland, MI	Jerry Arens & Amber Door
JUN	06-01	Monthly Board Meeting	Delta Imports, Grand Rapids, MI	WMR PCA Club
	06-10	Wednesday Night Cruise-In	Gilmore Car Museum, Hickory Corners, MI	Rick Riley
	6-13	Euro Autowerks Open House	Rockford, MI	Tim Thatcher and Euro Autowerks
	06-21 through 06-27	Porsche Parade 2015 PCA National Event	French Lick, IN	Porsche Club of America, National Event, Susan Brown
	06-27	Parade Orphans Lunch Drive	Destination TBD	Len & Bonnie Gawron
JUL	07-06	Monthly Board Meeting	Delta Imports, Grand Rapids, MI	WMR PCA Club
AUG	08-01	Red Barns Spectacular	Gilmore Car Museum, Hickory Corners, MI	Amber Door & Jerry Arens
	08-03	Monthly Board Meeting	Delta Imports, Grand Rapids, MI	WMR PCA Club
	08-21 through 08-22	28th Street Metro Cruise	28th Street SE, Grand Rapids, MI	Non-PCA Event
SEP	09-14	Monthly Board Meeting	Delta Imports, Grand Rapids, MI	WMR PCA Club
	09-26	Sept. Dinner Drive	Destination TBD	Dan & Ren Phillips
	09-30	PCA Escape 2015 Escape to Rushmore	Black Hills of South Dakota	Porsche Club of America, National Event
OCT	10-05	Monthly Board Meeting	Delta Imports, Grand Rapids, MI	WMR PCA Club

For more PCA National and Inter-Regional events, visit: <https://www.pca.org/events>



PORSCHE

ADDITIONAL EVENTS WILL BE ADDED AS THEY BECOME AVAILABLE

	Date	Event	Location	Host(s)/Event Chair(s)
OCT	10-05	Monthly Board Meeting	Delta Imports, Grand Rapids, MI	WMR PCA Club
	10-09 through 10-11	Porsche Rennsport Reunion V	Mazda Raceway Laguna Seca, 1021 Monterey Salinas Hwy, Salinas, CA 93908	Porsche Cars North America
	TBD	Annual Fall Color Tour	Destination TBD	TBD
NOV	11-02	Annual Planning Dinner	Destination TBD	WMR PCA Club
	11-07	November Dinner Drive	Destination TBD	Randy & Linda Portoluri
DEC	12-01	Monthly Board Meeting	Delta Imports, Grand Rapids, MI	WMR PCA Club
	12-12	December Appetizer Party	West Olive, MI	Mike & Barbara Karluk



© Porsche Cars North America

MOTORSPORT EVENTS CLOSE TO HOME

	Date	Event	Location	Host(s)/Event Chair(s)
AUG	TBD	IROC Series I – III	Destination TBD	Duane Weed, Michael Betz
	08-07 through 08-09	Driver Education Event	Gingerman Raceway, South Haven, MI	South-East Michigan Region PCA (SEM)
SEP	09-12 through 09-13	Grand Prix of Grattan DE	Grattan Raceway, Grattan, MI	Ted Blacklidge

For the full PCA Club Racing Schedule, visit: <https://www.pca.org/club-racing>

DEMING'S IIII Auto Collision Body Shop Service Inc. Since 1957

Owners Rob & Sue Deming, PCA Members since 1987



Deming's restored the body of Dan Bird's beautiful black concours-winning Porsche 356. This car was commented on by judges as "straightest body they had ever seen" at a California Porsches-only car show.

- Hagerty Insurance approved/preferred facility
- We work with all insurance companies
- Repairing all makes & models, foreign & domestic

Two experienced technicians, each with 10 to 20 years in the business

We can also help you with:

- Professional paint detailing services
- Concours-winning restoration services

2493 W. State Rd.
Hastings, MI 49058
E-Mail: info@demingsautocollision.com
Phone (269) 945-2922



- Many photos of projects in process
- Meet our crew
- Get in touch



**MOSAIC WEALTH
MANAGEMENT LLC**
Ted Vogt and Carol Dehen
LPL Registered Principals

5150 Cascade Rd SE, Grand Rapids, MI 49546
(616) 949-0900 (866) 949-0907
Securities offered through LPL Financial
Member FINRA/SIPC

Come Join Us for a Week of Fun!
June 21-27, 2015

Activities you can enjoy:

- Autocross
- Concours
- Rallies
- Tours
- Tech Sessions
- Social Events
- Kids Events
- More

Rated the Best Historic Resort
by Historic Hotels of America, 2013

Spas • Golf • Casino • Stables • Carriage Rides • Trolley



Registration opens
March 17, 2015
at 12:00 Noon EST

Learn More and Register at parade2015.pca.org



Great Lakes Chemical Detailing & Auto Appearance

870 40th Street SE * Grand Rapids, MI 49508 * 616-246-5134

www.glchemical.com



- * Paint Corrections
- * Interior Detailing
- * Scratch Removal
- * Road Paint Removal
- * Odor Abatement
- * Paint Protection with Coupon Service

**The Experts in
Hand Washing
And Professional
Auto Detailing!**

" After 27,000 miles of Michigan driving and 18 DE track days at Grattan and Gingerman, our beloved 2007 Porsche 911 Turbo was brought back to showroom appearance by Great Lakes Chemical. It looks almost better than new. A big thanks to Terry and Curt for the outstanding job."

- Ted and Gabriele Blacklidge

Hand Polish - \$129 OR Machine Wax - \$60



Get your WMR PCA Name Badge!

These are very high-quality name badges, permanently printed on a sturdy framed plate. The magnetic attachment won't damage your clothes. Cost is \$15 each, free shipping! Please send your check and correct name spelling to:

John Walters
2578 Selkirk Lake Dr
Shelbyville, MI 49344-9525

Please make your check payable to WMR PCA.

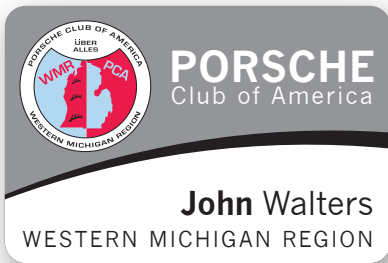



Specializing in the Service and Sales of Foreign Automobiles
269-342-6994

Acura - Audi - BMW - Bentley - Honda - Infinity - Jaguar
KIA - Land Rover - Lexus - Mazda - Mercedes
Nissan - Porsche - Saab - Toyota - VW - Volvo



WE EMPLOY TECHNICIANS
CERTIFIED BY ASE.
PLEASE LET US SHOW YOU
THEIR CREDENTIALS

Like Us On
facebook 

www.ForeignCarServices.com
Serving Enthusiasts since 1987

A higher level of service at a better value!
Complete high performance tuning for Club Racers.
Enjoy complimentary Keurig coffee, water and
free WiFi in our comfortable Customer Lounge!



269-342-6994
Visit us at our NEW location:
8730 Shaver Rd
Portage, Michigan 49024
Hours: M-F 8am - 5:30pm

GERMAN AUTO Service, LTD.

Serving the West Michigan Porsche community for over 30 years!

- Routine maintenance to track proven upgrades
- Outstanding customer service
- State of the art diagnostic equipment
- ASA master certified technicians
- Free shuttle service
- Conveniently located near downtown Grand Rapids

10% OFF PARTS FOR PORSCHE CLUB MEMBERS!



(800) 260-8000
www.germanautoltd.com
1014 Scribner NW
Grand Rapids, MI 49504



GLEN GORDON

231-995-0041



LAKESIDE
AUTOMOTIVE
Maintenance and Repair
www.LakesideAutoTC.com

3439 CASS ROAD TRAVERSE CITY, MI 49684

- Porches are Our Passion
- All PCA Member Receive **10% OFF PARTS**
- We Can Also Service **ALL** Your Other Vehicles

Hours: Monday-Friday, 8-5
Over 30 Years German Car Experience





Contributed by WMR PCA member
 Tim Thatcher, ASE-Certified Master Technician
 and Owner, Euro Autowerks

CABIN FILTERS - EASY DIY MAINTENANCE

Porsche began using cabin filters in 1995 on their 911 (933) cars, and with just basic technical knowledge and abilities you can replace them when needed.

CABIN FILTERS (POLLEN FILTERS) PLAY AN IMPORTANT ROLE IN A CAR'S HEATING AND AIR CON SYSTEM, TRAPPING POLLEN AND DEBRIS.

Though they may cost a little more, we always recommend you use a charcoal activated filter when possible, to help control smells and improve overall air quality.

Eventually, even under normal conditions, the filter becomes plugged. This decreases airflow into the system causing poor heating and cooling performance. Changing the filter in your car on a regular basis can help maintain a pleasant driving experience.

REPLACING FILTERS ON A 1995 - 1998 911 (933)

Open the hood and remove the plastic cowl cover by the windshield. There are two filters, one on each side of the blower housing.

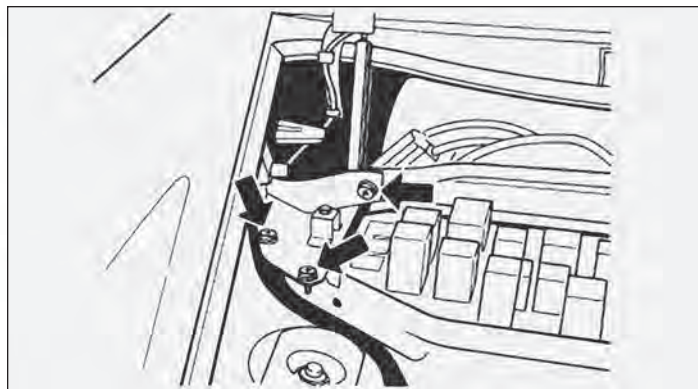
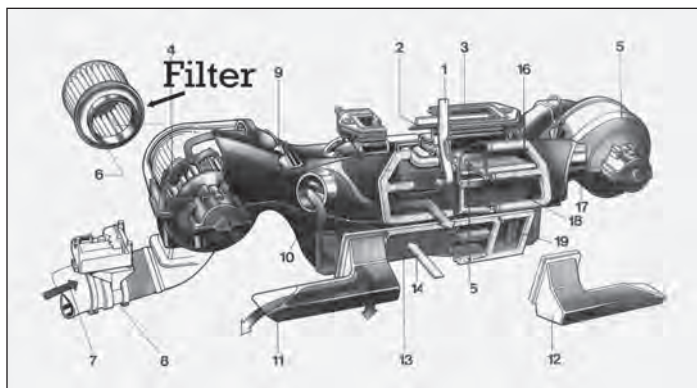

1. Remove the thumb screws on the top of the filter cover.
2. Remove the wiring that runs across the top of the filters.
3. Using a flat bladed screw driver, unclip the lower metal clips and slide the top cover upwards.
4. Lift the filters out.
5. Take note of the position of the tab on the filter (it should be facing up for proper installation).
6. Clean any debris out of the filter area.
7. Install new filters, paying attention to the position of the tab for proper installation.
8. Reinstall the wiring that was removed.

When reinstalling the filter cover, be sure you have it installed in the grooves so it slides down and seals correctly.

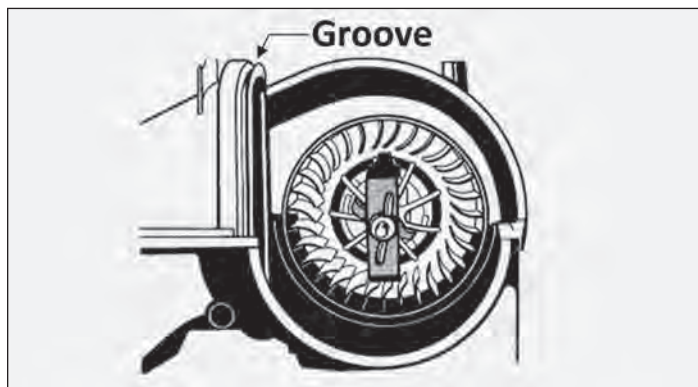

IN THE NEXT ISSUE WE COVER:

Replacing Filters on a 1999 (996, 997) 911, Boxster or Cayman, Cayenne.

Just a few more weeks and spring will be upon us. Flowers will bloom, trees will leaf out and we'll all be able to bring our cars out of storage. Spring is such a wonderful time, and we look forward to seeing you "on the road again" soon. — Tim

WMR MEETING MINUTES

FEBRUARY 2, 2015

Delta Porsche, Grand Rapids, February 2, 2015

Meeting was called to order by Mike Karluk at 7:01 pm.

Members present were: Ted Blacklidge, Gabi Blacklidge, Marshall Walters, Amber Door, Joyce Lo, Colin Carpenter

Treasurer's Report: Approved.

Membership Report:

Primary Members: 276
Affiliate Members: 190
Total Members: 466
New Members: 2
Transfers In: 0
Transfers Out: 1
Non renewals: 1
Renewals: 20

Minutes: January meeting minutes were reviewed and approved.

Über Alles Editor's Report:

February issue went to print 1/28/15.

Über Alles was entered into the PCA Newsletter contest.

Parade Ad for French Lick is in current Über.

Webmaster's Report: No report.

Social Media Report: Continue Facebook posts. Anticipate posts regarding upcoming Parade to encourage participation.

Insurance Report: No report.

Old Business:

- Leo's Dinner event - 1/14/15 - Host: Rick Riley
Great turn out for the event
- Board candidate: WMR is still seeking VP candidate

New Business:

- Winterfest - 2/21/15 - Invitations have been seen. Volunteer gift in process. Host: Brenda Hildon-Kaempf
Winterfest Committee Chair
- Morning After Brunch, 2/22/15, Charley's Crab at noon
Host: Amber Door / Jerry Arens

Meeting was adjourned 7:28 pm

Respectfully submitted by Brenda Hildon-Kaempf

CHAIRPERSONS · SERVING YOUR CLUB

Über Alles Editor:

Wolfgang Hofmann
(616) 730-1372
wmrpca@wolffhofmann.com

Webmeister:

Craig Paull
wmr.pca.org
pca.wmr.webmeister@gmail.com

Social Media Chair:

Joyce Lo
(616) 920-9998
wenpeng.lo@gmail.com

Interim Advertising Co-Chair:

Ted Blacklidge
(616) 866-4143
sgrafex@chartermi.net

Interim Advertising Co-Chair:

John Walters
(269) 672-5055
jwalters@wmis.net

Chief Driving Instructor:

Terry Schieble
(269) 329-1578
no39rsr@sbcglobal.net

AutoCross Event Chair:

Duane Weed
(231) 250-9624
duane@dwwideo.com

Safety Chair:

Craig Ackerman
(616) 866-1905
pcaackerman@aol.com

Historian & Insurance Coordinator:

Kurt Wirth
(616) 956-0249
kurtwirthsc356@comcast.net

Membership Chair:

Jerry Arens
(616) 457-4515
jdarens62@aol.com

Registrar:

Amber Door
(616) 457-4525
amdoor242@aol.com

WMR Enthusiast:

Marshall Walters
(269) 672-5055
marshall.walters@towerswatson.com

Zone 4 Representative:

Michael Soriano
(419) 843-2070
MSoriano.ZoneRep@gmail.com

CLASSIFIEDS

HARDLY USED OR ABUSED



1983 944 FOR SALE — \$2995.

Sienna Red Met. w/drk. brown int.; Car is a four time nat'l AutoX champion; One owner, meticulously maintained; Mechanically sound, runs & drives great; Only 85,000 miles on current engine; Only 5,000 miles on belts, rollers, and water pump; New windshield and battery, K&N air filter; Corbeau sport seats, Headers, cat test tube; Strut tower brace, Adjust. sway bars (28mm front, 22mm rear); Upgraded torsion bars, Koni "Yellow" Sport adjust. shocks/struts; Front springs upgraded to 400 lbs.; Slotted rotors, Semi-metallic brake pads, Stainless steel braided brake lines, ATE Super Blue brake fluid. Call (616) 540-3275.

2000 PORSCHE BOXSTER S

Silver w/red interior. 6 Speed MT. All original @ 84,000 miles except motor replaced @ 43,000 miles by Delta for IMS issue. Good general condition, new tires (less than 10,000 miles) in 2013. Time to move on to a 911 so need to sell — \$15,000 firm. Currently in winter storage but will be glad to fire up for serious inquiries. Haig Kassouni—616-901-2677 or Hkassouni@nkmfgtech.com

AUTO DETAILING SERVICE

References available. Call or e-mail Eric at Professional Car Appearance, LLC, (616) 706-4421 or ericpca911@yahoo.com.

WANTED!

Front Nose-Bra for 2012–2015 Boxster 981; call Jim Ziech at (269) 268-0240

ADVERTISING RATES:

The ÜBER ALLES magazine is published monthly by the Western Michigan Region of the Porsche Club of America.

Full page:

Color: \$105/month
Black & White: \$70/month

1/2 page:

Color: \$70/month
Black & White: \$45/month

1/4 page:

Color: \$45/month
Black & White: \$30/month

1/8 page:

Color: \$30/month
Black & White: \$20/month

Note: Color ads receive premier placement. Contact editor for exact size requirements.

Deadline for ad delivery and payment is the 15th of each month.

Please send your ads to:

Wolfgang Hofmann
PO Box 9877
Wyoming, MI 49509
wmrpca@wolffhofmann.com
Phone (616) 730-1372

CLASSIFIEDS:

Free for WMR members, \$3 for non-region PCA members, \$5 (2 lines) or \$10 (4 lines) for non-PCA members (3 months)

Note: Members must contact editor to renew. Editor reserves right to edit ads. Please refer to prices above.

PAYMENT:

Please make checks payable to: WMR PCA

THE TAILPIPE

BY WOLFGANG HOFMANN, ÜBER ALLES EDITOR

Congratulate these fine folks on their WMR PCA Anniversaries and extend a warm "Willkommen" to our new members and transfers.

Glückwünsche! — Anniversaries

5 years Ed Blackwell
(2010) Richard & Kathy Dirrenberger
Jack & Eileen Kooreman
Scott Poulton

Willkommen! — New Members

Thomas Saxe, Grand Rapids · '11 911
Robert Shuster, Grand Rapids · '09 Boxster

From Concept to Completion, we're helping
make the home of your *dreams*,
a *reality*.

Specializing in Residential Building & Remodeling for over 25 years

“The results of our Remodel Project, from concept to design and construction to finished product, can be summed up simply:

All aspects exceeded our expectations. We highly recommend the Morris Builders, Team!

We really have enjoyed our relationship with you and your staff, Remodeling should always be this easy and fun. Thank you for making our experience wonderful.”

- Dick & Fran Leonard



Joy Morris | Kirk Morris, CGR, CAPS, CGP
P: 616.874.6110 | MORRISBUILDERSINC.COM | Rockford, MI

THE TAILPIPE

BY WOLFGANG HOFMANN, ÜBER ALLES EDITOR



Wolfgang Hofmann
Über Alles Editor,
Western Michigan Region

Survey Comment:

Non-Porsche owners are confused by the Über Alles name and think it has something to do with the Nazis of WW2 Germany.

This was one of many interesting comments from our December survey. Let's look to our club

history. In 1972 our newsletter was addressed to, or called “Porsche Pushers”. In September of that year, we have the first issue, titled as Über Alles. Done with a typewriter and 3 pages long. I don't have any knowledge what prompted the change, but chances are, it was born out of admiration for our cars. Full stop. The end. — Interestingly, the Über Alles name did prompt me to pause, when I received my first Über Alles in the mail. I remember thinking to myself. No-one in Germany would name their newsletter like this. Why? — History.

Without historical context – the Über Alles expression, simply means “above all else”, or arguably better than everything else. The phrase itself is borrowed from the “Deutschland Lied” (Song of Germany), the German national anthem composed by Joseph Haydn and written by A. H. Hoffmann von Fallersleben around 1841.

Fun fact: Germany wasn't actually founded until 1871.

Fast-forward to 1932 and the start of Nazi rule. Three stanzas comprise the original song from 1841, of which the Nazis decided to use only the first stanza. Probably no need to elaborate why they thought the stanza with “Über Alles” in it, was just what Hitler ordered.

After the German people were liberated from the Nazis in 1945, it wasn't until 1952 that Germany decided to adopt only the third and last stanza as the official German national anthem. Holding true to the spirit of 1871 but staying well clear of any and all mentions of Über Alles.

WESTERN MICHIGAN REGION,
PORSCHE CLUB OF AMERICA
C/O Wolfgang Hofmann
PO Box 9877
Wyoming, MI 49509

PRSRST STD
U.S. POSTAGE
PAID
GRAND RAPIDS, MI
PERMIT NO. 404

Über Alles is the official monthly publication of the Western Michigan Region of the Porsche Club of America, Inc., a non-profit organization registered with the state of Michigan. Statements and opinions appearing herein are those of the authors and do not necessarily represent the opinions of WMR PCA, PCA, its officers or members. The editor reserves the right to edit all material for publication and to publish only the material deemed appropriate and in the best interest of WMR PCA and of PCA. Permission is granted to reprint in whole or in part, provided that A) credit will be given to the author(s), Über Alles, and WMR PCA, B) copyright is not involved, and C) a copy of the article is provided to WMR PCA upon publication. Subscriptions for non-members are \$18.00 annually. Deadline for advertising & new content is on the 20th day of the month prior to the issue month. Über Alles is available electronically at <http://wmr.pca.org/>.

LOOKING FOR AWARD WINNING PERFORMANCE & EXPERTISE?

Find it at
West Michigan's #1
Independent Porsche
Repair Facility

"In the 10 years I have taken my cars to Euro Autowerks, Tim and his staff have never let me down. If you value excellent service, reasonable prices, impeccable honesty and a personal relationship with your technician, it's the place for you."

Ed Blackwell, WMR -PCA Member

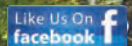

MEMBER
SINCE 1974



9240 Belding Road
Rockford, MI 49341
(616) 874-7932

www.euroautowerks.com
MON - FRI 8AM TO 5:30PM
Since 1984

PCA Member Discounts Available

Specializing in:
Porsche, Mercedes Benz, BMW,
Audi, Volkswagen, Volvo & SAAB

**EURO
AUTOWERKS**
INC.

Porsche Is Our Passion