



PORSCHE CLUB OF AMERICA Uber Alles Western Michigan Region

Let's Get Together:

Tech Session at Euro Autowerks
Spring UP to Traverse City

Tech Spalte:

Porsche Electric Power Steering

Article:

Porsche debuts new 911 Speedster

In Review:

May Dinner Drive
Sporting Clays

This is what happens when German engineers start families.

Power. Speed. Room for five. The new Cayenne is a true sports car for the whole family. Especially whoever gets to sit behind the wheel. Porsche. There is no substitute.

**The new Cayenne.
Sportscar Together.**



Porsche Grand Rapids
6025 28th Street SE
Grand Rapids, MI 49546
(616) 988-9797
porsche-grandrapids.com

©2019 Porsche Cars North America, Inc. Porsche recommends seat belt usage and observance of traffic laws at all times. European model shown. Some options may not be available in the U.S.



PORSCHE



PORSCHE



IGNITION

JUNE, 2019



AUGUST EVENTS

Red Barn Spectacular

August 3, 2019

Gilmore Car Museum

Hickory Corners, MI

Hosted By: Jerry Arens & Amber Door

August Dinner Drive

August 17, 2019

Hosted By: Tyan & Lisa Roelands

German Auto Service

Open House and Car Show

August 17, 2019

Hosted By: German Auto Service

28th Street Metro Cruise

August 23, 2019

Hosted By: Porsche Grand Rapids

More information to come in the July 2019 Über Alles

In this Issue...

President's Letter	4
2019 Porsche Parade	4
June/July Events	5 • 6
In Review	7
2019 Events Calendar	8
2019 Grattan Driver's Education	9
Tech Spalte	12
Officers & Chairpersons	13
Classifieds	14
Tailpipe	15

Show your Support by Visiting Our Advertisers!

Porsche Grand Rapids.....	Inside Front Cover
Deming's Auto Collision	10
Lakeside Automotive	10
Great Lakes Chemical.....	10
Hubbs Insurance, Inc.	11
Foreign Car Services.....	11
German Auto	11
Stickman Bäckererei.....	11
WMR PCA Badge	15
Mosaic Wealth	15
WMR PCA Über Alles Editor.....	15
Euro Autowerks.....	Back Cover

On the cover:
Sporting Clays, a Gentleman's and Lady's Sport.
Perfect complementary sport for Porsche Club members.

Photo by: Amber Door

Taken at Blendon Pines Gun Club during the Annual Sporting Clays Outing

! PORSCHE CLUB OF AMERICA

Über Alles

Western Michigan Region

GREAT SEASON OF EVENTS

LETTER FROM THE PRESIDENT



Jim Chiavaras

President,
Western Michigan Region

Greetings to All,

I am hopeful that June and July will bring dry and sunny weather for what will be a great start to the summer season of events.

May included a dinner drive to the Timbers Inn hosted by Glenn and Lannie Eisenbrandt and Frank and Raeni Conner as well as the ever-popular sporting clays at Blendon Pines Gun Club hosted by Jerry Arens and Amber Door, neither of which I was able to attend. Coming up in June we have the Belle Isle Grand Prix as well as the Open House and Tech Session with Tim Thatcher at Euro Autowerks and Spring UP to Traverse City. In addition, we have added a New Member Cars and Coffee Gathering in June, graciously hosted by Porsche Grand Rapids.

July brings us the Deutsche Marques event (not a WMR PCA sponsored event, but supported by many WMR PCA members) and the Wednesday Night Cruise-In hosted by Rick Riley both at the Gilmore Car Museum which are always a good time with quite a wide array of vehicles. Also in July is our Annual Porsche Parade in sunny Boca Raton. I hope everyone is getting their cars in-tune and ready, including their air conditioners!

I recently came across an interesting article/video of a Porsche Type 64 first built by Ferdinand Porsche himself as an early attempt at a rear engine sports car, production was however halted when WWII began. The vehicle referenced was the third and last Type 64 ever produced and the Porsche family kept the car for personal use. This could become the most valuable Porsche ever produced sold, estimated to be worth \$20-25 million and will be up for auction at Sotheby's in August if anyone from our region is interested. To watch a short video on the Type 64, go to <https://www.cnn.com/videos/business/2019/05/23/porsche-auction-ferdinand-sothebys.cnn-business/video/playlists/business-drive-cars/>

All The Best,

-Jim



PORSCHE PARADE 2019 REGISTRATION IS NOW OPEN!

Everybody Boca!

PORSCHE PARADE 2019 HEADS TO THE FLORIDA BEACHES

July 21 - 27, 2019

Parade Registration: What You Need to Know for Phase 2

The Phase 2 Registration process is only a few weeks away and PCA wants to provide an overview on what you need to know for the Phase 2 registration process. PCA encourages the local regions to join this informational webinar, "[What you Need to Know for Phase 2](#)" on **Apr 2, 2019 9:00pm EDT**. PCA wants to answer common questions on wait lists, cancellation policy, refund policy, making a schedule for yourself before you ever log in, etc. Click [here](#) for more information on the webinar. You can join the webinar by clicking this [link](#). You can also head to our [WMR PCA Website](#) for more information.

ACCESS THE MONTHLY MEETING MINUTES ON OUR WEBSITE.

[HTTP://WMI.PCA.ORG/ABOUT-US/MINUTES/MINUTES-ARCHIVE/](http://wmi.pca.org/about-us/minutes/minutes-archive/)



We're looking for event hosts for 2019

Simply stop by our Monthly Board Meeting, or contact our WMR PCA Social Events Coordinator, Lynne Olenyk, with your event ideas. Lynne will help you work through the details and make your event a success. E-Mail: lynniemarie@charter.net · Phone: (616) 710-0122



30TH ANNUAL SPRING UP

HOSTED BY: BOB STEFFENS

Now in its 30th year – join us for the WMR Spring UP! What started out as a small social gathering of the WMR membership that attended the 1989 Porsche Parade has grown to one of the most popular events of the WMR driving season.

We will plan to gather on the June 22nd at the Hagerty Garage located in Traverse City at 1:00pm. The Garage is located off 3 Mile Rd north of the airport. We will have some time there to see the facility, socialize and admire our fellow members' cars.

Following our time at the Hagerty Garage we will head out at about 2:30pm for a group drive through the beautiful Leelanau Peninsula with our final destination at the [Leland Lodge](#) at about 4:00pm. Dinner will be a buffet (~\$25.00 per person) and a cash bar will be available.

Think Spring in beautiful northern Michigan!
We'll see you there.

WEDNESDAY NIGHT CRUISE-IN

HOSTED BY: RICK RILEY

Has it stopped raining yet? I hope so, if it hasn't, I Noah a guy! I liked that joke!

July 17th we are going to drive independently and meet at the [Gilmore Car Museum](#) for one of their "Cruise-Ins". Every Wednesday evening during the summer the Museum hosts a come one, come all car gathering on the Museum grounds. You can see everything from a Rat Rod to a steam car and everything in between. They serve burgers, brats and beer! Other tasty morsels are available in "George & Sally's Blue Moon Diner" Ice Cream and Root beer floats are also available.



We will park on the street as you enter the Museum grounds proper beyond the gate in front

of the Franklin and Ford Model A buildings, so let's have a street full of Porsches! If you haven't visited the Museum come early and check out the display of Duesenbergs! This collection of cars is worth over \$128,000,000! They are rolling works of art. There is an entry fee of \$15.00 for the Museum but the Cruise-In is no charge.

RSVP: Call Bob Steffens at (248) 425-8297 by Wednesday, June 12, 2019

MEET UP: Hagerty Garage
2830 Aero Park Dr
Traverse City, MI 49686



WHEN: Saturday, June 22, 2019
1:00 pm (Meet Up)
2:30 pm (Drive around Leelanau Peninsula)
4:00 pm (Dinner)

DINNER: [Leland Lodge](#)
565 Pearl St.
Leland, MI 49654



There is no formal program. Come, eat, drink and check out all the cars. If you are coming from the Grand Rapids area I suggest you try the Yankee Springs road. Very scenic and fun.

Rob Clark and I will be there early so mark your calendar and come down and join us for a no stress, relaxing evening.

See you down the road.....Rick

WHERE: Gilmore Car Museum
6865 Hickory Road
Hickory Corners, MI 49060

WHEN: Wednesday, July 17, 2019
9:00 am (Museum Open)
5:00 pm (Cruise-In Start)



EURO AUTOWERKS OPEN HOUSE & TECH SESSION

HOSTED BY: TIM THATCHER & EURO AUTOWERKS

PCA Member Since 1974

Like Us On facebook
For more great pictures!

WELCOME!

Western Michigan Region
Porsche Club of America
PCA Member Discounts Available

West Michigan's #1 Independent Porsche Repair Facility.

Specializing in:
Porsche, Mercedes Benz, BMW,
Audi, Volkswagen, Volvo & SAAB

EURO AUTOWERKS, INC.

9240 Belding Road
Rockford, MI 49341
(616) 874-7932

www.euroautowerks.com
MON - FRI 8AM TO 5:30PM
Since 1984

Porsche Is Our Passion

JOIN US FOR OUR
2019 WMR-PCA
OPEN HOUSE
& TECH SESSION
JUNE 8, 2019
10am - 1pm
(Lunch provided)

NEW MEMBER GATHERING

HOSTED BY: WMR PCA & PORSCHE GRAND RAPIDS

Have you joined the Porsche Club of America / Western Michigan Region or transferred to the Western Michigan Region (WMR) within the last 12 - 24 months? Have you never been to a Club Event? Would you like to meet fellow WMR Porsche Club of America (PCA) members who share the same passion and love of the Porsche marque? PCA and WMR is not just about the cars, it's about the people. We are truly a diverse, fun and laid-back group of enthusiasts that enjoys the friendships that are forged through membership and common bonds. We would love to meet you or see you again if you have been able to participate in events since joining. To that end, we would like to cordially invite you to a New Members Cars and Coffee gathering so that we can introduce ourselves and the Western Michigan Region of PCA.

Please join us for Cars, Coffee and Conversation (and something to eat of course) at Porsche Grand Rapids. No RSVP required. Just come on by. We will gather starting at 8:30am until 10:00ish.

Looking forward to Meeting You!

WHERE:  **PORSCHE GRAND RAPIDS**
6025 28th St SE
Grand Rapids, MI 49546

WHEN: Saturday, June 15, 2019
Starting at 8:30am



IN REVIEW: MAY DINNER DRIVE

PHOTOS BY: AMBER DOOR

BY: GLENN EISENBRANDT

We had a wonderful turnout of 19 cars with 36 people for a great spring drive though the country side northeast of Grand Rapids. There were sufficient turns, curves and open straight-aways to make the drive interesting along with sufficient interesting scenery. An interesting note is we had cars of many different types from air cooled and front engine to some of the latest models and many different colors, except red (this would not happen if we were a Ferrari club).

Everyone made it though the 44 mile drive to end at Timbers Inn Restaurant & Tavern in Rockford, although a couple people tried to create their own route and needed to be herded back on track (of course the driver blamed it on his navigator). We were even lucky enough to have it not rain, until we were parked at the restaurant that is. You know Michigan in the spring.

When we arrived at Timbers we were escorted to our own area with a large fireplace, which we convinced them to turn on because of the cool spring weather.

We enjoyed a great meal where we had a choice of 4 different entrees and refreshments of choice along with great fellowship at a location many of the participants did not even know existed.

Craig Ackerman didn't make it for the drive but joined us at Timbers for dinner and fellowship, as did Rex Tsui and Joyce Lo. Rex and Joyce arrived in their newly acquired 991 Coupe. The drive from Chicago was just a little too far to get back in time for the drive. While other commitments kept club member and owners of Timbers, Dean Juth and Lisa Porcellii from joining us for all of the festivities, Lisa did join us for the drive in their Panamera.

As a welcomed bonus, joining us for the first time, we had three couples at the event who are new members - Bill & Kitty Blessing, Jim & Kelly Palmer and Tom & Cindy Lyon. Always great to see new faces and cars. Hopefully we will see all of them at future events.



Not a Red Porsche in sight



Glenn Eisenbrandt directing traffic

IN REVIEW: SPORTING CLAYS SHOOT-OFF

BY: JERRY ARENS & AMBER DOOR

The weather for the 2019 Sporting Clay and lunch event was perfect for an air-cooled car - not too hot and no rain! We welcomed new club members Jim Palmer and his sons Alec and Chase, as well as Bill and Kitty Blessing to their second WMR event in 7 days, as well as PCA junior members Savannah & Parker Bursck along with Dad - CB to the event this year.

Twenty-one shooters took to the woods on foot and on golf cart to hone their skills or for some, learn how to

shoot at a moving orange target. The seven cheerleaders did just that - cheered them on!

Our top shooters of the day were - male: Gary Buth & Rick Riley and female: Linda Wondergem.

Following the walk in the woods we took a short drive for lunch at Uccello's to enjoy a meal together - a nice end to a great day -- because we all know that PCA family members like to have a nice meal together.



*Gary Buth, Co-Top Male Shooter
Making the shot*



*Rick Riley, Co-Top Male Shooter
Intently watching his competition with
Bette Toliver*



*Linda Wondergem, Female Top Shooter
with sons Jared (far left) & Keegan (left),
husband Joel (behind), Craig Paull (right)
and host Jerry Arens (far right)*

2019 EVENT CALENDAR

WESTERN MICHIGAN REGION · PORSCHE CLUB OF AMERICA

	Date	Event	Location	Host(s)/Event Chair(s)
JUN	06-01 to 06-02	Belle Isle Grand Prix Porsche Car Corral	Belle Isle Detroit, MI	PCA
	06-03	Monthly Board Meeting	Porsche Grand Rapids	WMR PCA
	06-08	Tech Session	Euro Autowerks Rockford, MI	Euro Autowerks
	06-15	New Member Gathering	Porsche Grand Rapids	WMR PCA & Porsche Grand Rapids
	06-22	Spring UP	Northern Michigan	Robert Steffens
JUL	07-01	Monthly Board Meeting	Porsche Grand Rapids	WMR PCA
	07-06	Deutsch Marques: A German Auto Event	Gilmore Car Museum Hickory Corner, MI	Non-WMR PCA Event
	07-17	Gilmore Cruise In	Gilmore Car Museum Hickory Corners, MI	Rick Riley
	07-21 to 07-27	2019 Porsche Parade	Boca Raton Resort & Club Boca Raton, FL	PCA
AUG	08-03	Red Barn Spectacular	Gilmore Car Museum, Hickory Corners, MI	Jerry Arens & Amber Door
	08-05	Monthly Board Meeting	Porsche Grand Rapids	WMR PCA Club
	08-16	WERKS Reunion - Monterey	Corral de Tierra Country Club Salinas, CA	PCA
	08-17	August Dinner Drive	TBD	Tyan & Lisa Roelands
	08-23 to 08-24	28 th Street Metro Cruise Kickoff	Porsche Grand Rapids	Porsche Grand Rapids
SEP	09-04 to 09-07	Treffen Vermont Fall 2019	Woodstock Inn & Resort Woodstock, VT	PCA
	09-07 to 09-08	Grand Prix of Grattan High Performance Driver's Education	Grattan Raceway, Grattan, MI	Ted Blacklidge
	09-09	Monthly Board Meeting	Porsche Grand Rapids	WMR PCA
	09-21	Porsches and BBQ	Allegan, MI	CB & Kelly Bursk
	09-28	September Dinner Drive	TBD	Randy & Lin Portoluri
OCT	10-07	Monthly Board Meeting	Porsche Grand Rapids	WMR PCA
	TBD	Fall Color Tour	TBD	TBD
NOV	11-04	2020 Planning & Board Meeting	TBD	WMR PCA
	11-16	November Dinner Drive	TBD	Randy & Lin Portoluri
DEC	12-02	Monthly Board Meeting	Porsche Grand Rapids	WMR PCA
	12-07	Annual Appetizer Party	West Olive, MI	Mike Karluk & Barb Doss



PORSCHE

2019 GRAND PRIX OF GRATTAN

Lloyd LaHuis Memorial Grand Prix of Grattan Driver's Education, September 7 & 8, 2019

HOST: WESTERN MICHIGAN REGION PORSCHE CLUB



HPDE EVENT REQUIREMENTS:

Helmets: Mandatory Snell SA 2010 or newer. M helmets ok.

Vehicles: All cars must be inspected by a mechanic with a completed pre-event Inspection Sheet, available on the WMR website or contacts below.

Track Insurance (optional): Available at hagerty.com, locktonmotorsports.com or trackinsurance.com

Registration: Open June 1 at ClubRegistration.net.

Cost: \$330 for 2 days; \$190 for 1 day
After August 25 \$360 for 2 days; \$220 for 1 day.

DIRECT QUESTIONS TO:

Event Chair: Ted Blacklidge
sgrafex@chartermi.net or (616) 635-7997

Event Registrar: Amber Door
amdoor242@aol.com or (616) 340-0971

Event Safety and Technical: Eric Spross
ericpca911@yahoo.com

Join us for an exciting weekend at Grattan Raceway, one of the finest road courses in America, located just 20 minutes Northeast of Grand Rapids for our annual High Performance Driver's Education (HPDE) event. Learn how to maximize your driving performance on the two-mile course through the challenges of twists, turns, hills and valleys.

Instructors are available for a limited number of students, track and classroom instruction included. Register early to reserve a spot. Experienced drivers are welcome in performance cars. Registered drivers may share a car if they have different skill levels, as they will be assigned different run groups. Single day registration also available. Experienced only on Sunday.

Can't commit to a weekend? Join us on Saturday or Sunday (or both days!) for the Noon Hour Charity Laps. For a donation of \$20 per vehicle, experience the track at controlled speeds with family and friends. All proceeds from the Charity Laps will go to Family Promise of Grand Rapids. The mission of Family Promise of Grand Rapids is to end homelessness, one family at a time, by engaging faith-based and community organizations to provide emergency shelter and basic needs to families with children who are homeless and to provide additional programs to assist them in finding housing and sustaining their independence. Charity Laps will begin promptly at 12:00pm. Be at the gate by 12:00pm.



For more PCA National and Inter-Regional events, visit: <https://www.pca.org/events>



When: September 7 & 8, 2019

Where: Grattan Raceway
7201 Lessiter Rd NE
Belding, MI 48809

For more information, go to:
<http://wmi.pca.org/events/grand-prix-of-grattan/>



For the full PCA Club Racing Schedule, visit: <https://www.pca.org/club-racing>

facebook.com/wmrcpa



DEMING'S III Auto Collision Service Inc.

Find us on
Facebook

- Hagerty Insurance approved/
preferred facility
- We work with all insurance companies
- Repairing all makes and models,
foreign & domestic
- Three experienced technicians with
over 50 years of experience

2493 W. State Rd.
Hastings, MI 49058 demingsautocollision.com
(269) 945-2922 demingsrv.com

HAGERTY Approved & Preferred
WMR PCA Member Since 1987

GLEN GORDON

231-995-0041



LAKE SIDE AUTOMOTIVE

Maintenance and Repair

www.LakesideAutoTC.com

3439 CASS ROAD TRAVERSE CITY, MI 49684

- Porsches are Our Passion
- All PCA Member Receive **10% OFF PARTS**
- We Can Also Service **ALL** Your Other Vehicles

Hours: Monday-Friday, 8-5
Over 30 Years German Car Experience



WMR PCA Member Since 2013



Great Lakes Chemical Detailing & Auto Appearance

870 40th Street SE * Grand Rapids, MI 49508 * 616-246-5134

www.glchemical.com



- * Paint Corrections
- * Interior Detailing
- * Scratch Removal
- * Road Paint Removal
- * Odor Abatement
- * Paint Protection with
Coupon Service

The Experts in Hand Washing And Professional Auto Detailing!

"After 27,000 miles of Michigan driving
and 18 DE track days at Grattan and
Gingerman, our beloved 2007 Porsche 911
Turbo was brought back to showroom
appearance by Great Lakes Chemical. It
looks almost better than new. A big thanks
to Terry and Curt for the outstanding job."

- Ted and Gabriele Blackledge

Hand Polish - \$129 OR Machine Wax - \$60





**HUBBS
INSURANCE, INC.**

**Agreed Value Insurance
Compare with Any National Company
Local West Michigan Agency**

Auto • Antique Auto • Agreed Value Autos • Home • Commercial

Agents: Jon Leslie & Judy Swartz

**Call or email us today or stop by
(877) 984-6066 or (616) 754-9359**

hubbsinsur@hotmail.com

125 E. Cass Street Greenville, MI 48838



Specializing in the Service and Sales of Foreign Automobiles

269-342-6994



Acura - Audi - BMW - Bentley - Honda - Infinity - Jaguar
KIA - Land Rover - Lexus - Mazda - Mercedes
Nissan - Porsche - Saab - Toyota - VW - Volvo



www.ForeignCarServicesMi.com

Serving Enthusiasts since 1987

A higher level of service at a better value!
Complete high performance tuning for Club Racers.
Enjoy complimentary Keurig coffee, water and
free WiFi in our comfortable Customer Lounge!



269-342-6994

Visit us at our NEW location:
8730 Shaver Rd
Portage, Michigan 49024
Hours: M-F 8am - 5:30pm

WMR PCA Member Since 1995

GERMAN AUTO Service, LTD.

**Serving the West Michigan Porsche
community for over 30 years!**

- Routine maintenance to track proven upgrades
- Outstanding customer service
- State of the art diagnostic equipment
- ASA master certified technicians
- Free shuttle service
- Conveniently located near downtown Grand Rapids

**10% OFF PARTS FOR
PORSCHE CLUB MEMBERS!**



(800) 260-8000
www.germanautoltd.com
1014 Scribner NW
Grand Rapids, MI 49504



STICKMANN BAECKEREI
— Old World Bakery & Bistro —

**Beginning 6/26 —
Fridays through Sundays:**

We will be featuring
our German-Style
Curry Sausage —
with a side of Sweet
Potato Salad or Loaded
Baked Potato Salad

**Don't forget to stop by
and pick up:**

Authentic German Sausages
(Knackwurst, Weisswurst,
Sheboygen, or Smoked
Chicken and Apple)
or Organic Cheese
(Lamont Cheddar,
Country Dill or Edam)

Full Breakfast and Lunch Menu

Lattes, Cappuccinos and Specialty Drinks
Fresh Baked Bread, Scones, Muffins, Cookies and more!

**Present this advertisement at the time of purchase
for 10% off your order of \$25 or more.**

11332 W M 179 Hwy · Middleville, Michigan
Phone (269) 205-2444
Mon-Fri: 6am-3pm and Sat-Sun: 7am-3pm
WMR PCA Member Since 2003

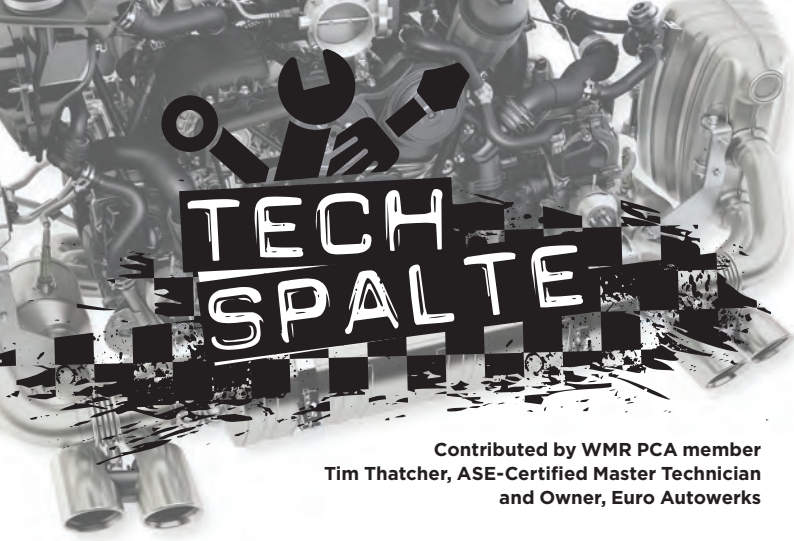

Contributed by WMR PCA member
**Tim Thatcher, ASE-Certified Master Technician
 and Owner, Euro Autowerks**

PORSCHE E.P.S (ELECTRIC POWER STEERING)

WHY THE PORSCHE SYSTEM STILL GIVES THE DRIVER FEEDBACK INFORMATION

Some advantages the electric system has over the hydraulic system that it replaced:

- No more need for a pump and hoses
- No more messy leaks from lines, pump or steering racks
- No engine drag from running a pump
- The ability to have power assist with start or stop technology

As with most automotive systems, EPS systems continue to evolve with changes made to improve handling and feel.

The conventional E.P.S used on many cars leave a lot to be desired when it comes to feeling the road, making one feel

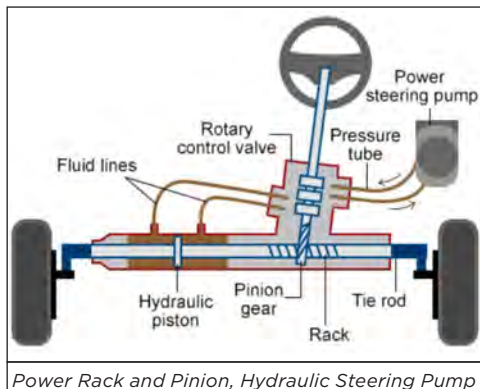

Power Rack and Pinion, Hydraulic Steering Pump

like a passenger rather than driver. They are fixed rate or “graph” units, and the assist does not change with road force or adapt to driving conditions. While this makes for a smoother

driving car, it gives very little feedback.



Conventional systems are considered “top down” systems, whereby the motor and control are along the steering shaft and operate on a fixed graph.

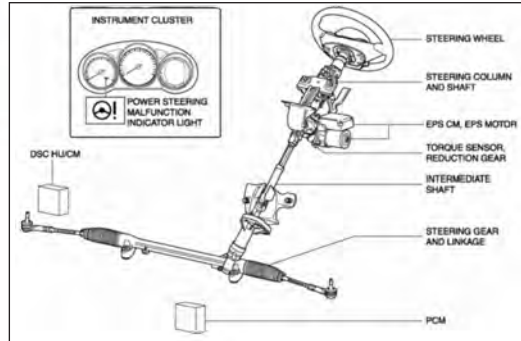

*Electric Rack and Pinion Steering.
 Note motor and control unit mounted above the Rack and Pinion. Top down control with motor.*

Porsche E.P.S. is considered a “bottom up” system since the motor is on the steering rack itself. This allows Porsche to leave the amount of assistance

open and controlled by the Porsche rack force controller.



*Electric Rack and Pinion Steering.
 Note motor is mounted parallel to the Pinion for “Bottom Up” control of motor.*

Porsche’s E.P.S system uses information including the steering angle, turn rate and loads of other information provided by the Stability Control System Sensors, to vary the

amount of assistance.

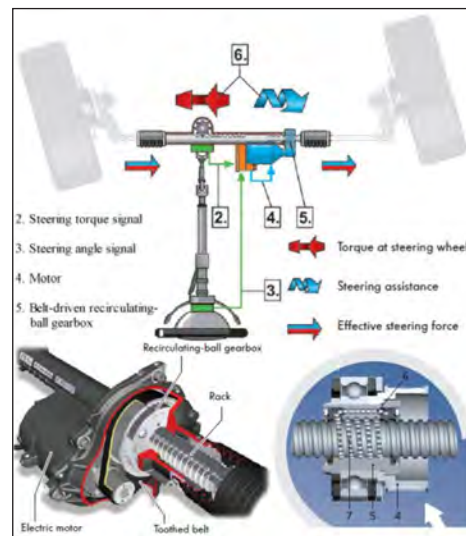

The Porsche E.P.S. system transfers rotational motion to axial motion ball through the use of ball bearings. Such a system produces less friction, which allows more true information to be transferred to your hands.

Because Porsche E.P.S. uses many factors to control the assist, they can tune in the road feel (feedback) in real time. Still giving us the experience we love. (The feeling of driving the car and not just being driven.)

I look forward to seeing each of you at our Tech Session/Open House on June 8th . We’ve been assured that the weather will be great and we’ve got a special tech session presentation that you will not want to miss.

See you there!
 -Tim

OFFICERS

SERVING YOUR CLUB



Jim Chiavaras
President,
2014 Cayman S

7505 Old Lantern Dr
Caledonia, Mi 49316
(616) 293-5862
jpcco@comcast.net



Frank Conner
Vice President,
2012 Carrera GTS

3820 Egypt Valley Ave NE
Ada, MI 49301
(616) 874-4085
connerfr@gmail.com

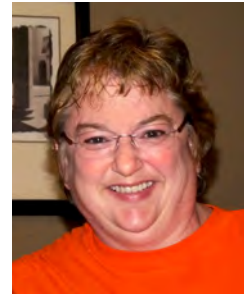

Marshall Walters
Secretary,
2014 Cayman ("Precious")

2578 Seymoure Drive
Shelbyville, MI 49344
(616) 780-1210
marshallwalters911@gmail.com

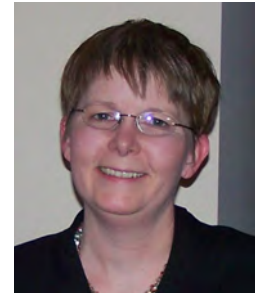

Amber Door
Treasurer,
1984 Porsche 911 Coupe

645 Summerset Dr.
Jenison, MI 49428-7938
(616) 340-0971
amdoor242@aol.com

JERRY DILLINGER

We lost another long-time Porsche-pusher this past week. Jerry Dillinger, who many of you have met over the years, passed away unexpectedly at the age of 74. Jerry lived in Suttons Bay with his wife, Mary. Early on, Jerry became known as fierce competitor (just ask Rick Riley) who ably represented Motorstadt Region at a variety of driving events. He was also a wonderful friend who will be sorely missed. WMR sends its condolences to Mary and family. His obituary can be found at <https://www.reynolds-jonkhoff.com/obituaries/Gerald-Dillinger-2/#!/Obituary>.



CHAIRPERSONS · SERVING YOUR CLUB

Über Alles Editor:

Lina Spross (616) 706-4422
uberwmr@gmail.com

Webmeister:

Craig Paull wmr.pca.org
pca.wmr.webmeister@gmail.com

Social Media:

Joyce Lo (616) 920-9998
wenpeng.lo@gmail.com

Social Events Coordinator:

Lynne Olenyk (616) 710-0122
lynniemarie@charter.net

Membership:

Jerry Arens (616) 457-4515
jdarens62@aol.com

Insurance Coordinator:

Tyan Roelands (616) 295-5715
tyanroelands@gmail.com

Historian:

Chuck Olenyk (616) 258-9575
olenyks@chartermi.net

Interim Advertising Co-Chair:

Ted Blacklidge (616) 866-4143
sgrafex@chartermi.net

Interim Advertising Co-Chair:

John Walters (616) 260-1082
jwalters@wmis.net

Charity:

Lin Portoluri (616) 842-9266
lindaportoluri@charter.net

High Performance Driver's Ed:

Ted Blacklidge (616) 866-4143
sgrafex@chartermi.net

Chief Driving Instructor:

Jeff Kolk (616) 836-3524
kolkrcing@gmail.com

AutoCross Event:

Michael Betz (616) 460-8880
mmbetz@image-stream.com

Safety Chair:

Eric Spross (616) 706-4421
ericpca911@yahoo.com

Registrar:

Amber Door (616) 340-0971
amdoor242@aol.com

WMR Enthusiast:

Glenn Eisenbrandt (269) 312-4984
GEisenbrandt@ssoe.com

Zone 4 Representative:

Lori Schutz (972) 890 7405
Scmink2@earthlink.net



CLASSIFIEDS

HARDLY USED OR ABUSED

2013 BOXSTER



23,920 miles. Sport Chrono package, Porsche PDK, sport seats, 19-inch Boxster S wheels with color Porsche crest wheel caps, Bi-Xenon Headlights with PDLs. Asking \$37,900. Contact Jim for additional information and pictures at jpcdo@comcast.net or (616) 293-5862.616-534-5513

2009 911 CARRERA



29,950 miles, second owner. White with grey leather. Sunroof, PDK, Heated Seats & Steering Wheel, Bose High End Sound, XM Radio, Launch and Power Comfort Seats!

Within last 1,000 miles :

Oil & filter change, brake fluid flush, new serpentine belt, new spark plugs, new coils/tubes, cabin air filter and engine (3.6) air filters!

Always in heated garage! Purchased from Porsche Dealer May 2017. This car is a cream puff, excellent condition and never tracked. Only selling due to another recent Porsche purchase. \$46,000 Request photos, call or text. Mike Oltersdorf (231) 632-0123

RARE PORSCHE PARTS

(4) 6 X 15 Fuchs wheels, P/N 911.361.020.10, 1975 date code, black centers, rim edges are untouched. Purchased in 1992 from Stuttgart House of Parts in Mooresville, NC for 914 project. Never mounted. \$1600 / OBO. Contact Bob Johnson at E-Mail: laser314@att.net or call (616)393-5990

911 TRACK TIRES



Set of four wheels/tires that will fit a 911. Great for track events or a new look for your Porsche. Only \$500.00 or best offer. For more information contact Bill White. Call or text (616) 836-1287 or email: bwhite@harboryachtsales.com.

1972 914 PARTS FOR SALE

Parts from a 914 used to fix another 914. These parts are in good shape. The following are available: interior parts and panels, dash parts and instruments, windows, body trim, tail lights, brake and engine parts plus other miscellaneous items. For a full list contact Randy Portoluri at (616) 842-9266 or rportoluri66@charter.net. I may have just what you need!

PORSCHE BOOKS

101 Projects For Your Porsche 911 (1964-1989) and *Porsche 911 Performance Handbook*. Excellent condition. \$50 for both. Contact Greg Calahan at 616-617-0369 or gcalahan@mac.com.

PORSCHE 911 PARTS

Miscellaneous box of odds-and-ends (bolts, jack, small parts, etc.). Make me an offer! Contact Greg Calahan at 616-617-0369 or gcalahan@mac.com.

911 FUCHS AND TIRES FOR SALE

Wheels and tires in good condition. Front: 911362113, 6 x 16, ET36, 205 55 R16 Rear: 911362115, 7x16, ET23.3, 225 50 R16 Tires: Yokohama Advan A048 \$1300 (set). Contact Eric Spross at (616)706-4421 or ericpca911@yahoo.com

AUTO DETAILING SERVICE

References available. Call or e-mail Eric at Professional Car Appearance, LLC, (616)706-4421 or ericpca911@yahoo.com.

ADVERTISING RATES:

The ÜBER ALLES magazine is published monthly by the Western Michigan Region of the Porsche Club of America.

Full page:

Color: \$105/month
Black & White: \$70/month

1/2 page:

Color: \$70/month
Black & White: \$45/month

1/4 page:

Color: \$45/month
Black & White: \$30/month

1/8 page:

Color: \$30/month
Black & White: \$20/month

Note: Color ads receive premier placement. Contact editor for exact size requirements.

Deadline for ad delivery and payment is the 15th of each month.

Please send your ads to:

Lina Spross
uberwmr@gmail.com
Phone (616) 706.4422

CLASSIFIEDS:

Free for WMR members, \$3 for non-region PCA members, \$5 (2 lines) or \$10 (4 lines) for non-PCA members (3 months)

Note: Members must contact editor to renew. Editor reserves right to edit ads. Please refer to prices above.

PAYMENT:

Please make checks payable to: WMR PCA



Photo from Sporting Clays Outing (taken by Amber Door)

Get your WMR PCA Name Badge!

These are very high-quality name badges, permanently printed on a sturdy framed plate. The magnetic attachment won't damage your clothes. Cost is \$15 each, free shipping! Please send your check and correct name spelling to:

Frank Conner
3820 Egypt Valley Ave
Ada, MI 49301



Please make your check payable to WMR PCA.



MOSAIC WEALTH MANAGEMENT LLC

*Ted Vogt and Carol Dehen
LPL Registered Principals*

4764 Fulton Street East, Suite 201

Ada, MI 49301

(616) 949-0900 (866) 949-0907

Securities offered through LPL Financial
Member FINRA/SIPC

WMR PCA Member Since 2012

THE TAILPIPE

Join me in congratulating these fine folks on their WMR PCA Anniversaries and extend a warm "Willkommen" to our new members and transfers.

Glückwünsche! — May Anniversaries

1 year (2018) Rick Glasser, David Pelizzari, Eric Tiller, Jane VanBemden

5 years (2014) Gordon & Cathy Kirsch, Julio Morales, David & Cherise Vander Heide, Dan & Christine White

Willkommen! — May New Members & Transfers

Jeff Huxley, '08 Cayman S, Alma

Richard Frutiger, '18 718 Cayman S, Alma

Scott & Janet Bjerke, '00 911 / '14 Cayenne Turbo, Kalamazoo - transfer in from North Country

Gary Kahle, '15 911 4S, Traverse City - transfer in from Ohio Valley

Patrick & Mary Kondart, Omena - home for Summer

Scott Kraai, Greenville - home for summer



WESTERN MICHIGAN REGION,
PORSCHE CLUB OF AMERICA
C/O Lina Spross

PRSR STD
U.S. POSTAGE
PAID
GRAND RAPIDS, MI
PERMIT NO. 404

Über Alles is the official monthly publication of the Western Michigan Region of the Porsche Club of America, Inc., a non-profit organization registered with the state of Michigan. Statements and opinions appearing herein are those of the authors and do not necessarily represent the opinions of WMR PCA, PCA, its officers or members. The editor reserves the right to edit all material for publication and to publish only the material deemed appropriate and in the best interest of WMR PCA and of PCA. Permission is granted to reprint in whole or in part, provided that A) credit will be given to the author(s), Über Alles, and WMR PCA, B) copyright is not involved, and C) a copy of the article is provided to WMR PCA upon publication. Subscriptions for non-members are \$18.00 annually. Deadline for advertising & new content is on the 20th day of the month prior to the issue month. Über Alles is available electronically at <http://wmr.pca.org/>.

EURO AUTOWERKS
INC.

**West Michigan's #1
Independent Porsche
Repair Facility.**

Specializing in:
Porsche, Mercedes Benz, BMW, Audi,
Volkswagen, Volvo, SAAB & Mini Cooper

EURO AUTOWERKS, INC.
9240 Belding Road
Rockford, MI 49341
(616) 874-7932
www.euroautowerks.com
MON - FRI 8AM TO 5:30PM
Since 1984
Porsche Is Our Passion
PCA Member Discounts Available

Like Us On facebook

MEMBER SINCE 1974

ASE
AUTOMOTIVE SERVICE EXCELLENCE

BOSCH SERVICE

"In the 10 years I have taken my cars to Euro Autowerks, Tim and his staff have never let me down. If you value excellent service, reasonable prices, impeccable honesty and a personal relationship with your technician, it's the place for you."

Ed Blackwell, WMR -PCA Member