



 PORSCHE CLUB OF AMERICA
Über Alles
Western Michigan Region

Let's Get Together:
End of Summer Fun Run
Oktoberfest

800 volts of Auf Wiedersehen.

Say hello to perhaps the most electrifying Porsche to ever come out of Stuttgart. The Porsche Taycan. A fast-charging 800-volt system architecture propels you from 0-60 in just 2.6 seconds - again and again. An advanced cockpit marvels driver and passengers alike. All infused with clear Porsche design DNA. Say goodbye, garage.

**Experience true electrified performance.
The all new Taycan Turbo S.**



Porsche Grand Rapids
6025 28th Street SE
Grand Rapids, MI 49546
616-988-9797
porschegrandrapids.com

© 2020 Porsche Cars North America, Inc. Porsche recommends seat belt usage and observance of traffic laws at all times.
European model shown. Some options may not be available in the U.S.



PORSCHE



Upcoming EVENTS

OKTOBERFEST

Garage Kept Motors and Euro Autowerks

September 22, 2023

FINN'S DINNER DRIVE

Randy & Linda Portoluri

November 11, 2023

APPETIZER PARTY

Mike & Barb Karluk

December 02, 2023

Keep an Eye on the [WMA PCA Website](#) and your e-mail for event details

PORSCHE CLUB OF AMERICA
Uber Alles
Western Michigan Region

IGNITION

SEPTEMBER 2023

In this Issue...

The Engine	4
President's Letter	5
In Review: Pool Party & BBQ	6
Snap Shots	7
2023 Event Calendar	8
In Review: Dinner Drive to Schulers	9
From the Editor: Juniors	10
Stuttgart Market Letter	11
Technolab	12 - 13
Classifieds	14
Oktoberfest	15
The Tailpipe - QR-Code & Ad	16

On-line, topics (text) are hyperlinked.

Return to here



Show your Support by Visiting Our Advertisers!

Porsche Grand Rapids.. Inside Front Cover	
WMA PCA Badge	5
Advance Wealth Management Service.....	5
German Auto	6
Hubbs Insurance, Inc.	6
Lakeside Automotive.....	10
Edward Jones	10
Foreign Car Services.....	11
Curries Furniture.....	15
Euro Autowerks.....	Back Cover

ON THE COVER

Winding road tour and dinner drive to Schulers. See review on page 9.

Photo by Wolfgang Bubeck
Camera: Sony A7IV
Lens: Tamron 28-75mm F2.8

THE ENGINE OF THE CLUB

OFFICERS · SERVING YOUR CLUB



Frank Conner
President,
2012 Carrera GTS

Ada, MI
(616) 874-4085
connerfr@gmail.com



Glenn Eisnebrandt
Vice President,
1970 914-6, 2007 Cayman S,
2016 Macan S

Grand Rapids, MI
(616) 312-4984
GEisenbrandt@ssoe.com



Marshall Walters
Secretary,
2014 Cayman ("Precious")

Shelbyville, MI
(616) 780-1210
marshallwalters911@gmail.com



Amber Door
Treasurer,
1984 Porsche 911 Coupe

Jenison, MI
(616) 340-0971
amdoor242@aol.com

CHAIRPERSONS · SERVING YOUR CLUB

Über Alles Co-Editors:

Wolfgang Bubeck (616) 780-6590
Lina Spross (616) 706-4422
uberwmr@gmail.com

Webmeister:

Craig Paull wmr.pca.org
pca.wmr.webmeister@gmail.com

Social Media:

Joyce Lo (616) 920-9998
wenpeng.lo@gmail.com

Social Events Coordinator:

Lynne Olenyk (616) 710-0122
lynniemarie@charter.net

Membership:

Jerry Arens (616) 340-2192
jdarens62@aol.com

Insurance Coordinator:

Tyan Roelands (616) 295-5715
tyanroelands@gmail.com

Historian:

Chuck Olenyk (616) 258-9575
olenyks@chartermi.net

WMR Enthusiast:

Glenn Eisenbrandt (269) 312-4984
GEisenbrandt@ssoe.com

High Performance Driver's Ed:

Greg Currie (231) 632-2232
greg@curriesfurniture.com

Chief Driving Instructor:

Jeff Kolk (616) 836-3524
kolkrcing@gmail.com

AutoCross Event:

Michael Betz (616) 460-8880
mmbetz@image-stream.com

Safety Chair:

Eric Spross (616) 706-4421
ericpca911@yahoo.com

Registrar:

Amber Door (616) 340-0971
amdoor242@aol.com

Zone 4 Representative:

Dave Stetson (614) 286-5988
<https://zone4.pca.org>

ACCESS THE MONTHLY MEETING MINUTES ON OUR WEBSITE.
[HTTP://WMI.PCA.ORG/ABOUT-US/MINUTES/MINUTES-ARCHIVE/](http://wmi.pca.org/about-us/minutes/minutes-archive/)

WESTERN MICHIGAN REGION ACTIVE MEMBERS · BUILDING THE CLUB

Total: 726

Primary Members: 461

Co-Members: 265

Honorary/Lifetime: 0

PCA Juniors: 41

GLÜCKWÜNSCHE! — ANNIVERSARIES

Join me in congratulating these fine folks
on their WMR PCA Anniversaries.

20 years (2003) Scott Hice

15 years (2008) Jeffrey & Weijing Schultz

10 years (2013) Frank & Kathleen Jeffreys
Robert Baker & Kimberly Fletcher

5 years (2018) Douglas German

1 year (2022) Nick Defoe
Edward & Ashlye Karaus
James Morrison

WILLKOMMEN! — NEW MEMBERS & TRANSFERS

Please extend a warm "Willkommen"
to our new members and transfers.

David Barger, Traverse City, '14 911 S
Trent Debrot, Rockford, '23 Macan T
John Phillippe, Kalamazoo, '19 911 GT3RS
Ralph Puertas, Traverse City, '14 Boxster S
William Reilly, Ada, '19 911 GTS

Transfer In:

Ed Devito (MST), Bellevue, '85 911



LETTER FROM THE PRESIDENT

LET'S HAVE SOME FUN!

Yes, the long running, Premier WMR Event is upon us, the End of Summer Fun Run. We will be at Grattan Raceway Park Friday September 8 through Sunday September 10. Regardless of your skill level, this is a great way to hone your driving skills and experience the lifeblood of a Porsche. If you can't make it for an entire day (or weekend), on Saturday and Sunday you have an opportunity to drive the track as part of our charity outreach. From noon - 1:00, anyone with a driver's license can drive on the track at normal traffic speeds without a helmet. No need to pre-register, just show up with \$20.00 and enjoy the time on the track.

An event new to the calendar is Oktoberfest Evening Open House at Garage Kept Motors sponsored by Garage Kept Motors and Euro Autowerks. The invite is for everyone to bring their Porsches and stop by between 5:30pm - 10:00pm with friends and family to celebrate their first annual Oktoberfest Evening Open House! Traditional German food and bier will be provided along with a wide array of beautiful German cars, including some rare metal from Stuttgart.

Looking through the rearview mirror, Saturday August 5 saw a large number of Porsches old and new (and one Mustang GT350 hanging just off the edge of the corral) at the Porsche Car Corral & Membership Tent at the Gilmore Car Museum Red Barn Spectacular. Thanks to our hosts, Amber Door and Jerry Arens. I was unable to attend because of a long standing tradition of attending the Weathertech Sportscar Championship at Road America. It was an exceptional weekend however as we watched the #7 Porsche 963 driven by Felipe Nasr and Matt Campbell take the overall win at the IMSA Sportscar Weekend.

Two great events last month well attended by members but not sponsored by the club were the Open House hosted by Porsche Grand Rapids on the evening of August 24 corresponding with the beginning of the 28th Street Metro Cruise. The second event was the next morning, an open house combined with a car show at German Auto Service. WMR members left Saturday afternoon with several door prizes and a best of decade award for the quintessential 1980's wall poster; a Guards Red Porsche 930 owned by Greg and Sandy Nyenhuis. (Shame on you if you thought the quintessential 1980's wall poster was a Ferrari Testarossa.)

Get your WMR PCA Name Badge!

These are very high-quality name badges, permanently printed on a sturdy framed plate. The magnetic attachment won't damage your clothes. Cost is \$15 each, free shipping! Please send your check and correct name spelling to:



Frank Conner
3820 Egypt Valley Ave
Ada, MI 49301

**Please make your
check payable to:
WMR PCA.**



The Winner: Guards Red Porsche 930 at German Auto Service

Frank

BY LOU DELEGUARDIA

The day was sunny with temperatures in the low 80's. Perfect weather for a pool party out in the country air. Most guest's arrived between 4 and 5 pm., parking their cars on a freshly mowed lawn. Approximately 17 guests drank adult beverages and had a nice conversation until dinner was served around 6 pm. We had a combination of salads and desserts. Michele and I cooked BBQ thighs and marinated chicken breasts. Brats, burgers were also served. Ty and Lisa brought their toddler son Liam. Ty couldn't get him out of the pool. I think Liam had the most fun. Paul and Rene played

a game of Corn-hole. Swimming was enjoyed by several members until the sun went down and everyone helped clean up before heading home. I hear a good time was had by all.



The majority of people opted for relaxing by the pool.



Ty and Liam, the most active participants.

GERMAN AUTO Service, LTD.

Serving the West Michigan Porsche community for over 30 years!

- Routine maintenance to track proven upgrades
- Outstanding customer service
- State of the art diagnostic equipment
- ASA master certified technicians
- Free shuttle service
- Conveniently located near downtown Grand Rapids

10% OFF PARTS FOR PORSCHE CLUB MEMBERS!



(800) 260-8000

www.germanautoltd.com

2189 Avastar Parkway, Suite A
Grand Rapids, MI 49544



HUBBS

INSURANCE, INC.

Agreed Value Insurance

Compare with Any National Company

Local West Michigan Agency

Auto • Antique Auto • Agreed Value Autos • Home • Commerical

Agents: Jon Leslie & Judy Swartz

Call or email us today or stop by

(877) 984-6066 or (616) 754-9359

hubbsinsur@hotmail.com

125 E. Cass Street Greenville, MI 48838





Red Barn Spectacular



The classic beauty of a 356



You can't go unnoticed in this American beauty



Great craftsmanship applied to preserve history

German Auto Service Open House



Citroën 2CV an iconic cheap car in Europe



GAS Open House with lot's of Porsches



Glenn Eisenbrandt with his REAL 6 914 at German Auto

Snap SHOTS

Pictures taken by
Wolfgang Bubeck

2023 EVENT CALENDAR



WESTERN MICHIGAN REGION · PORSCHE CLUB OF AMERICA

	Date	Event	Location	Host(s)/Event Chair(s)
SEP	09-08 to 09-10	WMR High Performance Driver's Education	Grattan Raceway Grattan, MI	3 DAYS WMR PCA
This is the End of Summer Fun Run. For further details and registration go to: clubregistration.net. Chair Person: Greg Currie - Contact info on page 4				
	09-11	Monthly Board Meeting	Ganders Restaurant	WMR Board
	9-22	Oktoberfest	Garage Kept Motors	Garage Kept Motors Euro Autowerks
OCT	10-02	Monthly Board Meeting	Ganders Restaurant	WMR Board
	TBD	Fall Color Tour	TBD	TBD
NOV	11-06	Annual Planning Meeting & Membership Meeting	TBD	WMR Board
	11-11	Dinner Drive	Finn's Chop House, Spring Lake	Randy & Linda Portoluri
DEC	12-02	Appetizer Party	The Karluk's	Mike Karluk & Barbara Doss
	12-04	Monthly Board Meeting	Ganders Restaurant	WMR Board



There were just Porsches on the Ganders parking lot for the board meeting. Photo by Frank Conner.

We're looking for event hosts for 2023

Simply stop by our Monthly Board Meeting, or contact our WMR PCA Social Events Coordinator, Lynne Olenyk, with your event ideas. Lynne will help you work through the details and make your event a success. E-Mail: lynniemarie@charter.net · Phone: (616) 710-0122



BY DAN PHILLIPS



Porsche talk at staging prior to the drivers meeting. Always a good time to make new friends.

A far-flung corner of our region, Marshall was once in competition to be the location of our state's capitol. Marshall is now well-known for its outstanding cross-section of 19th- and early 20th-century architecture,



Family style food of excellent quality was served.

featuring an annual tour of homes and several outstanding B&Bs. Even our destination, Schuler's, recently opened 6 beautiful boutique hotel rooms above the restaurant, making it a truly unique and fun destination for a weekend get-away.

Our group enjoyed a great buffet-style meal of London broil, chicken roulade, and pasta primavera with all the usual accompaniments and a nice desert selection. The service and food were absolutely first-rate as we enjoyed a private dining room for our group. Schuler's even worked with the city of Marshall to set aside VIP parking for us across the street to the south. All in all, it was a great event, and a reminder that great things can be found in just about every corner of our region!

On Saturday, July 22nd, 30 cars and 51 people gathered for a great drive through beautiful sun-soaked country roads down to Marshall, MI. The weather was positively gorgeous, with some moderate rainfall only in the last 5-6 miles of our 70+ mile drive. A suicidal turkey kept being indecisive on the side of the road along M-78, right after the Banfield Rd jog, but one of our participants unfortunately made contact with a racoon which took out a radiator, but resulted in our participants meeting a very nice car enthusiast who toured them through his collection while they waited for a tow. It helps to look for the silver linings!



Kelly and Thad Phelps observing the horses for the upcoming ride.



ADVANCE WEALTH MANAGEMENT SERVICE

Expertise in leading families through their financial lives

www.awm-s.com

NEW!!! PCA JUNIORS

[HTTPS://WWW.PCA.ORG/PCA-JUNIORS](https://www.pca.org/pca-juniors)

FROM THE EDITOR



JUNIORS
PORSCHE CLUB OF AMERICA
Monthly e-Newsletter

It's not just the cars... and now it's not just the grown-ups! This e-newsletter is produced for parents and sponsors of PCA Juniors and is intended to create engagement and interaction. PCA Juniors is a free program for young Porsche enthusiasts, under 18 years of age, who are registered by an active PCA member. Sponsoring PCA members will receive this monthly e-newsletter featuring information and activities for kids. We hope you enjoy and share this content with your PCA Juniors. For more information about the program [click here](#).



Activity of the Month

This month's activity is to create and crash a DIY car! The goal is to keep a plastic egg safely seated inside, and prevent its head from touching the ground in the event of a rollover accident.

This is a completely open-ended project. There's no right way to build it, but be sure to limit key materials like cups and rubber bands to encourage creative solutions!

Once this activity is completed, post a photo on our social media pages:

[PCA Juniors Facebook](#)
[PCA Juniors Instagram](#)
[PCA Juniors Twitter](#)

[Click here to watch the activity](#)

A snippet of the current JUNIORS newsletter

Hello, grown-ups. Did you know that the PCA.org includes information and events for juniors under the age of 18? Look at the link above. The website is still under construction, however you can find information that your youngster might be interested in. They will automatically receive the JUNIORS Newsletter if you sign them up (at no cost) and enter their email address.

Facebook and Instagram are the main social media platforms, but Twitter is also popular.

When searching PCA.org for JUNIORS, add the check-mark for News Articles/Blog Posts.

<https://www.pca.org/news/pca-juniors-events>

The events page is currently only a placeholder, but you can locate current and prior newsletters there.

Please foster the next generation's interest in Porsche's, including social events and new friendships.

GLEN GORDON 231-995-0041



LAKESIDE
AUTOMOTIVE
Maintenance and Repair
www.LakesideAutoTC.com

3439 CASS ROAD TRAVERSE CITY, MI 49684

- Porsches are Our Passion
- We Can Also Service ALL Your Other Vehicles

Hours: Monday-Friday, 8-5
Over 30 Years German Car Experience



WMR PCA Member Since 2013

Edward Jones

[edwardjones.com](https://www.edwardjones.com) | Member SIPC

Start your next chapter in life with a solid savings plan.

Bank-issued,
FDIC-insured

5.3 %

3-month APY*

Call or visit your local financial advisor today.



Lou Deleguardia, AAMS™

Financial Advisor
46 West Sheridan
Fremont, MI 49412
231-924-9600

* Annual Percentage Yield (APY) effective 06/28/2023. CDs offered by Edward Jones are bank-issued and FDIC-insured up to \$250,000 (principal and interest accrued but not yet paid) per depositor, per insured depository institution, for each account ownership category. Please visit www.fdic.gov or contact your financial advisor for additional information. Subject to availability and price change. CD values are subject to interest rate risk such that when interest rates rise, the prices of CDs can decrease. If CDs are sold prior to maturity, the investor can lose principal value. FDIC insurance does not cover losses in market value. Early withdrawal may not be permitted. Yields quoted are net of all commissions. CDs require the distribution of interest and do not allow interest to compound. CDs offered through Edward Jones are issued by banks and thrifts nationwide. All CDs sold by Edward Jones are registered with the Depository Trust Corp. (DTC).

FDI-1916M-A © 2022 EDWARD D. JONES & CO., L.P. ALL RIGHTS RESERVED. AECSPAD





STUTTGART MARKET LETTER

BY DAVID K. WHITLOCK

As expected, August topped all previous months of this year in terms of dollar volume and unit volume as 680 cars ran through the various auctions both online and in-person with \$58,551,955 in sales thanks to the auctions at Monterey's Car Week. The real surprise was the 66% sell-through rate, which is the lowest thus far in 2023.

Monterey, by itself, could be classified as a rough week for the Porsche Market, as only 61% of cars offered found new homes. The top of the market took the biggest hit, with cars over \$1m selling at only a 50% sell-through rate, with not a single car over \$2m hammering sold. We saw similar results online, with only one million-dollar car selling out of the five offered during the month. Only two of the \$1m+ cars sold were vintage race cars, with the rest being modern classics, a theme we've seen this year played out in auction after auction.

In August, we saw more 356s cross the block than in any other month in memory, with a total of 50 cars, 33 of which sold. After a solid recent price run, the 356 market shows signs of softening as several cars brought final bids on the lower pricing side. One example would be the 1956 356A 1500 GS Carrera Speedster that sold for \$850,000 at Mecum. This time last year, we saw a GS/GT example hammer down at \$1,325,000, quite a price difference. We've also had several recent online sales on the softer side, with a 1965 356C Coupe in superb condition bringing only \$126,000 when these were recently going for over \$130k.

911 Turbos were a mixed bag, with only half of the early 930s finding homes and the average price hovering just over \$150k, thanks partly to the \$405,000 and \$267,500 paid for a pair of 1979 examples. Others hovered in the \$130k range, with a low of \$90,000 paid for a 1978 911 Turbo. Later, 3.3-liter 930s looked flat with an exceptional car, the very first 911 Turbo Slant Nose, failing to sell at a high bid of \$181,000. That car was most likely about \$100k short of where it needed to be, as it's such a significant part of Porsche's Turbo history.

964 Turbos continued their climb, with average prices for 3.3-liter cars cresting the \$180,000 mark and 3.6-liter cars over \$330,000. Surprisingly, a 1994 911 Turbo S 3.8 only brought \$800,000, as these cars have been in the \$1m range until the past two months. 993 Turbo and Turbo S' also had a strong showing, with the lowest price paid being \$160,000 for a modified 1996 example repainted in Blue. On the other side of the coin, we had a new record achieved at \$810,000 for a sub-2,000-mile 1997 Turbo S finished in Cobalt with racing stripes to match the original owner's 917 and 935 race cars.

992 GT3s continued their slide with several bids in the \$240k range, and only one Touring example selling for over \$300k at Gooding & Co. The 991.1 GT3 RS showed some strength with an average sales price of around \$200k. Where the GT market looked its softest was with RSRs. Of the three examples offered, none found homes showing that they are either too new to be considered collectible race cars or sellers had hopes of much higher prices. Probably a combination of both.

As I write this, it is still too early to tell what September will bring as we're in the midst of a holiday weekend. But if August is any indication, I wouldn't be surprised if our sell-through rate remains below 70% and we start to see some new lows achieved for cars that have been climbing since COVID.

Specializing in the Service and Sales of Foreign Automobiles
269-342-6994

Acura - Audi - BMW - Bentley - Honda - Infinity - Jaguar
KIA - Land Rover - Lexus - Mazda - Mercedes
Nissan - Porsche - Saab - Toyota - VW - Volvo

WE EMPLOY TECHNICIANS
CERTIFIED BY ASE.
PLEASE LET US SHOW YOU
THEIR CREDENTIALS

Like Us On
facebook

www.ForeignCarServicesMi.com
Serving Enthusiasts since 1987

A higher level of service at a better value!
Complete high performance tuning for Club Racers.
Enjoy complimentary Keurig coffee, water and
free WiFi in our comfortable Customer Lounge!

269-342-6994
Visit us at our NEW location:
8730 Shaver Rd
Portage, Michigan 49024
Hours: M-F 8am - 5:30pm

WMR PCA Member Since 1995



First let's start with the basics. What is a brake?

By definition, a brake is a device for slowing or stopping the motion of a machine or a vehicle, or alternatively a device to restrain it from starting again. Following the fact that energy is never lost or created, only transformed, the energy that the car while in motion, called kinetic energy is transformed into heat by the friction created between the rotor and the brake pads. This energy increases exponentially with the speed of the vehicle, so if you double the vehicle's speed, the energy quadruples, if you triple it, the energy gets multiplied by 9 and so forth.

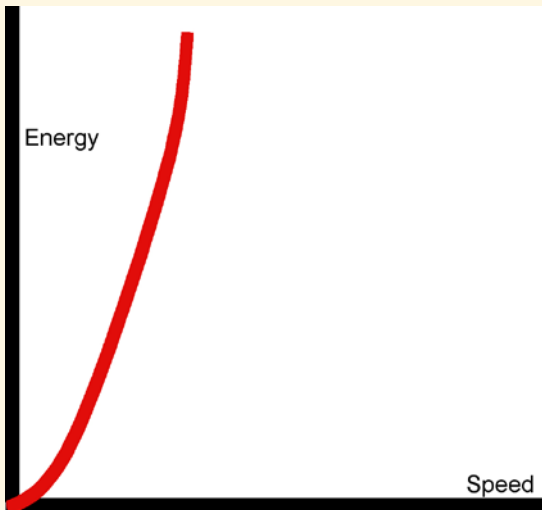

You can see how the graph looks. The kinetic energy lost by the moving part is usually translated to heat by friction.

The kinetic energy increases with the mass of the vehicle (m) and with the square of the velocity ($E = m \cdot v^2$). This means that as the speed (v) of the vehicle doubles, it has 4 times more energy and the brakes must therefore dissipate four times as much energy to stop, therefore using 4 times more distance.

This is perfectly illustrated in this Bob Chapman photo of Flying Lizard's No. 45 at the 12 Hours of Sebring from a couple of years ago. Notice how the front rotors start to glow red at the end of the long straights.

The racecar's kinetic energy being transformed into thermal energy (heat) that can actually be seen.

Porsche Brakes are legendary!

To put it into context: The Special Edition Boxster RS 60 with 303 HP can accelerate from 0-60 mph in 5.0 seconds (that's quite a feat) ... yet it can decelerate from 60-0 mph in 3.4 seconds! (that's a greater feat). Braking Power in a Porsche is several times greater than the power output of it's flat 6 engine.

Our cars now come with standard four-piston-monoblock-aluminum-fixed-calipers front and rear and cross-drilled and vented discs (also called rotors).

As far as brakes go, it doesn't get much better than that, unless ... you dish out another \$9,000 and get the same brakes that the Carrera GT came with: PCCB (Porsche Ceramic Composite Brakes).

Porsche Brakes Misconception

All Porsches come with Brembo Brakes. You can't imagine how many times people, even Porsche owners, who look at my wheels have said:

"You've upgraded your brakes!... You



DOOR PANELS DAMAGED ?



WE CAN PERMANENTLY REPAIR YOUR PORSCHE DOOR PANELS FOR A FRACTION OF THEIR REPLACEMENT COST!
LIFETIME WARRANTY ON THE REPAIR

PEDROSGARAGE

ONE PORSCHE AT A TIME



CALL US TO ARRANGE SHIPPING
(813) 749-0150
TURNAROUND IN 24-48 HOURS
WWW.PEDROSGARAGE.COM



installed Brembos". That couldn't be further from the truth. ALL modern Porsches come with factory Brembo brakes. If you don't believe me, go look at your calipers.



Let's get a little deeper into the brakes now. This illustration isolates the Braking System in our cars, showing all the braking components involved. You can see that at each corner you have a set of calipers with pads hovering over the disc and they are all connected through a system of mostly hard and some flexible lines to a pump that gets actuated by the brake pedal.

The ABS, or Anti-Locking Brake System which all of our cars also have, is a secondary system which operates in tandem with the Brake System. It's basically a safety feature in modern cars that doesn't allow any one of the tires to lock up under heavy or panic braking.

1. Backing Plate
2. Rotor (cross-drilled)
3. Caliper (4 piston)
4. Retainer and Pin
5. Spring
6. Dust Seals
7. Sensors
8. Pads
9. Lower Caliper Tube
10. Caliper Bolt

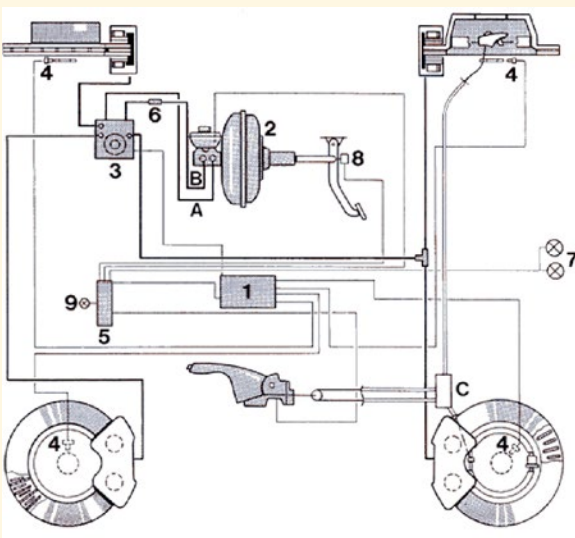
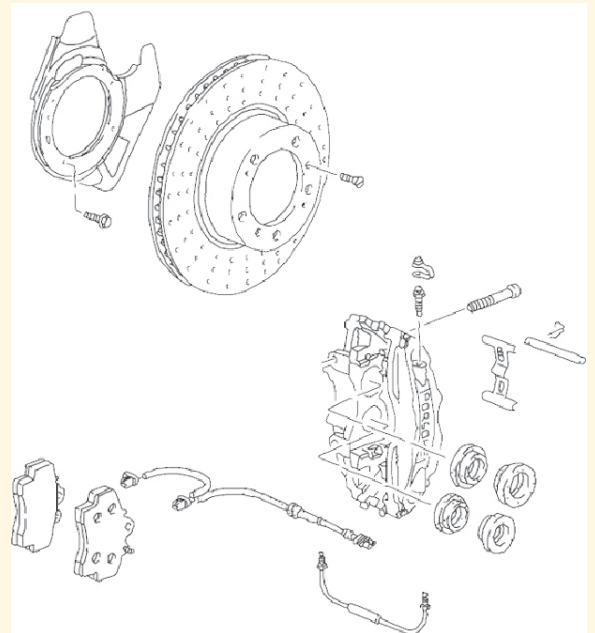

There's the:

1. ABS Control Unit which monitors each wheel's speed compared to the other three
2. Brake Unit which is made up of the Brake Booster and Master Cylinder
3. ABS Hydraulic Unit
4. ABS Speed Sensors, one in each corner which sample each wheel's individual speed and sends the information to the Central Information System
5. Central Information System
6. Brake Proportioning Valve
7. Brake Lights
8. Brake Light Switch
9. ABS Warning Light1 - ABS control unit

to be continued next month

CLASSIFIEDS

HARDLY USED OR ABUSED

H&R SPORT SPRING SET FOR 987 BOXSTER

2005-12, new in box. Lowers front approx. 1.4in., and rear 1.2in. part # 29168-1 \$250. picked up, or plus shipping.

Located in TC, or can possibly drop off en route to Kalamazoo, if you are not in a hurry.....tomrev2@yahoo.com



Set of 4 Michelin Latitude

Sport Tires 295/35 R21
Less than 200 road miles on these tires! Stored (individually wrapped) in a heated hangar for about 4 years.
Text Lina at 616 706 4422



Set of 6 Pirelli P Zero Tires

295/35 R21
Less than 200 road miles on these tires! Stored (individually wrapped) in a heated hangar for about 4 years.
Text Lina at 616 706 4422



PORSCHE CALENDARS & COINS

Porsche calendars from 1985 through 2005 with their coins. They are 23" x 22" in like new condition and in their original boxes. Missing 1992 and 2004 calendars and coins. No coin with 2000 calendar. No box for 2005 calendar. \$100 for the lot of 19 calendars and 18 coins. Contact Larry at (513) 722-6966.

EXCELLENCE FOR FREE

Approx.. 10 years of Excellence mages in boxes. Must be picked up at my home in Alanson MI. Will Need SUV to pick up, as the boxes are heavy. First year not complete. Text Lawrence at (231) 622-2481.

20 PC LUG NUT SET \$50

Full set of Alloy Closed End Lug Nuts from 1976 Porsche 911S. Worn but serviceable. Wheel locks not included. M14x1.5 Thread. Jim at 269-268-0240 or jziech@gmail.com



21" RS SPYDER FACTORY WHEELS



and Michelin Pilot Alpine 5 SUV snow tires. 275/40R21 fronts and 305/35R21 rears. 7,900 documented miles, from 2019 Cayenne S. Wheels are in perfect condition, asking \$3200 (new over \$6k). Contact Jeff @ b767pw@gmail.com

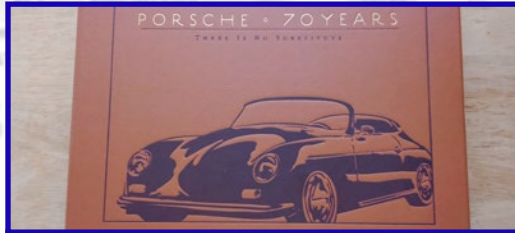

PORSCHE 70 YEARS - LEATHER BOUND (THERE IS NO SUBSTITUTE)

Brand New, in perfect shape. \$85 Local pick up in St. Louis, MI

SOFT TOP ROOF PROTECTOR

HALF COVER FOR PORSCHE BOXSTER 986 - 1997 TO 2004 (145G) - GREY
Like new, used only once - \$65 local pick up in St. Louis, MI. Contact (book & cover) brianbintc@gmail.com



911/914 STEERING WHEEL

914.347.804.11 with horn ring 901.613.805.0
Very good condition, pics available \$450.
E-Mail: mosierfamily@charter.net

PORSCHE PANORAMA'S

6/90 thru 6/99 free to a good home.
E-Mail: mosierfamily@charter.net

19" BLACK MSW WHEELS

Michelin Latitude X Tires - Like New 255/50 R19 - 235/55 R19 \$900 Pick up in Marshall, MI. varns4964@comcast.net or text 616-710-0656



ADVERTISING RATES:

The ÜBER ALLES magazine is published monthly by the Western Michigan Region of the Porsche Club of America.

Full page:

Color: \$105/month
Black & White: \$70/month

1/2 page:

Color: \$70/month
Black & White: \$45/month

1/4 page:

Color: \$45/month
Black & White: \$30/month

1/8 page:

Color: \$30/month
Black & White: \$20/month

Note: Color ads receive premier placement. Contact editor for exact size requirements.

Deadline for ad delivery and payment is the 15th of each month.

Please send your ads to:

Wolfgang Bubeck
Phone (616) 780-6590
uberwmr@gmail.com

CLASSIFIEDS:

Free for WMR members, \$3 for non-region PCA members, \$5 (2 lines) or \$10 (4 lines) for non-PCA members (3 months)

New:

Limited to buy or sell club related items only. Space for business ads needs to be purchased as listed above.

Note: Members must contact editor to renew after 2 month. Editor reserves right to edit ads.

PAYMENT:

Please make checks payable to: WMR PCA

COPPER COATED OIL TANK

Early 911 copper coated oil tank could be reconditioned. \$350 OBO. Call Randy at (616)842-9266 or (616)502-8959.
E-Mail: rportoluri66@charter.net



Amish Solid Wood Quality Never Goes Out Of Style
 Select your wood species, stain/paint, and size.



Celebrating 30 Years
Currie's Furniture
 "Saving You Money"



Locally Owned by
 PCA Members
 Greg & Karlene Currie



10% Off

PCA Members - Show this coupon at
 time of purchase to redeem.

In store purchase only. Excludes Closeouts, previous purchases, and other promotions.

Open Mon-Sat 10am-6pm
www.curriesfurniture.com
 (231)-943-8570

OKTOBERFEST EVENING & OPEN HOUSE

BY GARAGE KEPT MOTORS AND EURO AUTOWERKS

Oktoberfest Evening & Open House

September 22nd at 5:30pm at Garage Kept Motors- 420 36th St SE, Grand Rapids, MI 49548

In Germany, September means Oktoberfest! West Michigan Region PCA along with Garage Kept Motors and Euro Autowerks welcome everyone bring their Porsches and stop by between 5:30pm - 10:00pm with friends and family to celebrate our first annual Oktoberfest Evening Open House! Traditional German food and bier will be provided along with a wide array beautiful German cars, including some rare metal from Stuttgart. We look forward to seeing everyone there!

Please RSVP to Ty Roelands text 616-295-5715 or email TyanRoelands@gmail.com so we can make sure we have plenty of food and drinks for all!"



WESTERN MICHIGAN REGION,
PORSCHE CLUB OF AMERICA
C/O Wolfgang Bubeck
Belmont, MI

PRSR STD
U.S. POSTAGE
PAID
GRAND RAPIDS, MI
PERMIT NO. 404



Scan the QR code to access the current and all previous Über Alles Online Newsletters

Über Alles is the official monthly publication of the Western Michigan Region of the Porsche Club of America, Inc., a non-profit organization registered with the state of Michigan. Statements and opinions appearing herein are those of the authors and do not necessarily represent the opinions of WMR PCA, PCA, its officers or members. The editor reserves the right to edit all material for publication and to publish only the material deemed appropriate and in the best interest of WMR PCA and of PCA. Permission is granted to reprint in whole or in part, provided that A) credit will be given to the author(s), Über Alles, and WMR PCA, B) copyright is not involved, and C) a copy of the article is provided to WMR PCA upon publication. Subscriptions for non-members are \$18.00 annually. Deadline for advertising & new content is on the 20th day of the month prior to the issue month. Über Alles is available electronically at <http://wmr.pca.org/>. See QR code above.

EURO AUTOWERKS

Restoration - Preparation - Service



616.874.7932
euroautowerks.com

9240 Belding Road
Rockford, MI 49341

